

Base Station Antenna Catalogue



Contents

Overview	01
Customer Benefits	02
Product Portfolio	03
Single-band Antennas	05
Dual-band Antennas	36
Triple-band Antennas	43
Remote Electrical Tilt (RET)	45





Overview

Holding the consistent concept of customer orientation in mind, Huawei Agissson undertakes to enhance customer success by rapidly responding to customer demands and providing customers with profitable and sustainable base station antenna products and solutions through innovative technologies and outstanding operations.

In 2004, based on a deep understanding of wireless communication systems as well as the application experience in antenna, Huawei Agissson start the base station antenna self-development. Through years of efforts, Huawei Agissson has developed single-band, dual-band, and multi-band antenna series to meet the GSM / UMTS / CDMA / and TD-SCDMA / LTE /WiMAX and other system needs. Through strict testing and authentication, Huawei Agissson products have been gradually deployed by famous carriers in China and abroad, including Vodafone, STC, Telefonica, MTN, BSNL, ET, Zain, China Unicom, China Telecom, etc. At present, Huawei Agissson antennas have been deployed across the world and serve over 200 carriers in more than 90 countries.

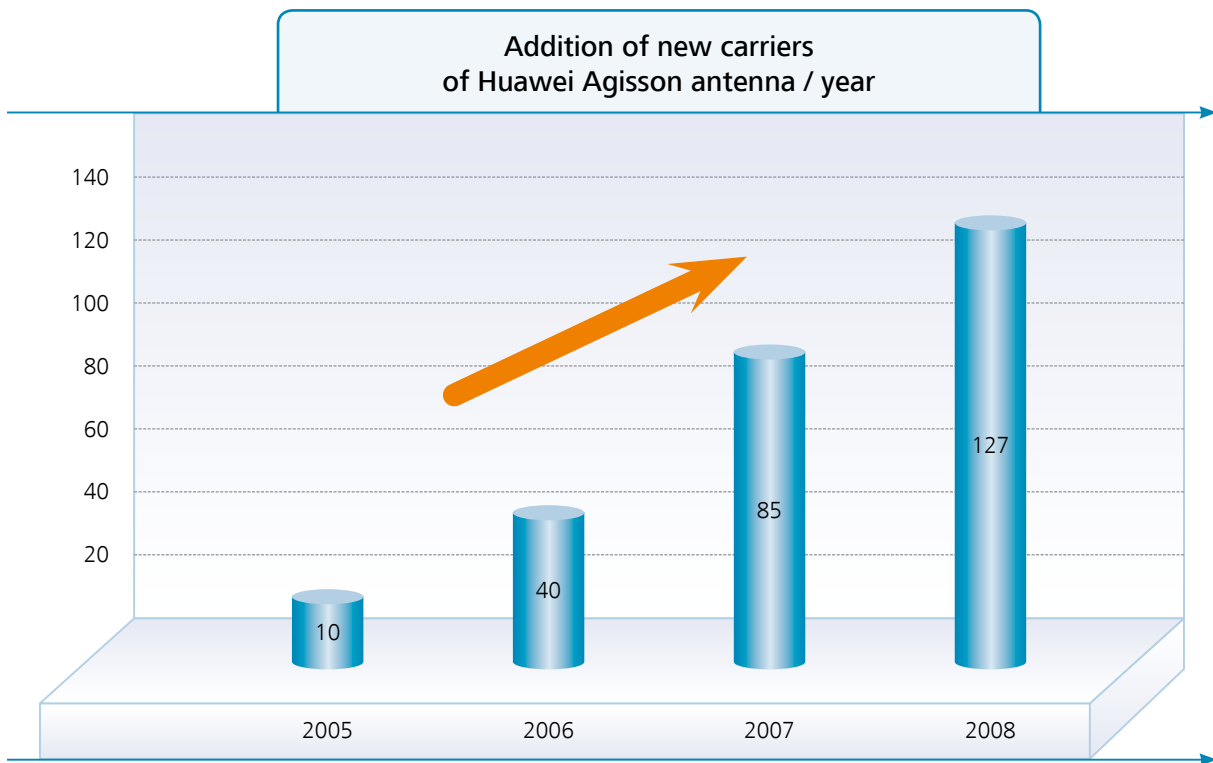



Customer Benefits

- **Excellent performance**

The electrical performance of Huawei Agissoon antennas is higher than the average level in the industry. The Passive Intermodulation (PIM), upper sidelobe suppression, and front-to-back ratio characterize have all reached or exceeded international leading standards.

- **Multiple IPRs**

Huawei Agissoon owns 17 open patents on core components and core technologies of base station antennas, such as radiation element and phaseshifter. In addition, 8 patents on antennas are being filed.

- **Enhanced product reliability through sophisticated techniques, complete inspection measures, and advanced procedure guarantee**

Huawei Agissoon boasts an Asian leading automatic antenna production line. Antenna workshop is equipped with 15 anechoic chamber . Have 2 external testing fields, and multiple-band antenna test instruments. In compliance with the advanced Integrated Product Development (IPD) procedure, coupled with the verification of the accurate open testing fields, Huawei Agissoon fully evaluates comprehensive product performance in the development process. Huawei Agissoon antennas provide you with stable and reliable network quality and can be deployed in diversified scenarios for long-run usage.

Asian leading automatic antenna production line



Automatic assembly line



Fully automatic production line for antenna

Anechoic chamber



Anechoic Chamber: Excellent testing environment for antennas



Production inspection in the anechoic chamber

Excellent manufacturing process and strict testing



Automatic soldering machine: automatically solders the parts as programmed



Icy test: tests the long-run durability of antennas in harsh environments such as low temperature



Product Portfolio

Single-band Antennas

- Cross Polarized Antennas, 450-470MHz
- Cross Polarized Antennas, 806-960MHz
- Cross Polarized Antennas, 1710-2170MHz

Dual-band Antennas

- Cross Polarized Antennas, 2x1710-2170 MHz
- Cross Polarized Antennas, 824-960/1710-2170 MHz

Triple-band Antennas

- Cross Polarized Antennas, 824-960/2x1710-2170 MHz

Remote Electrical Tilt (RET)

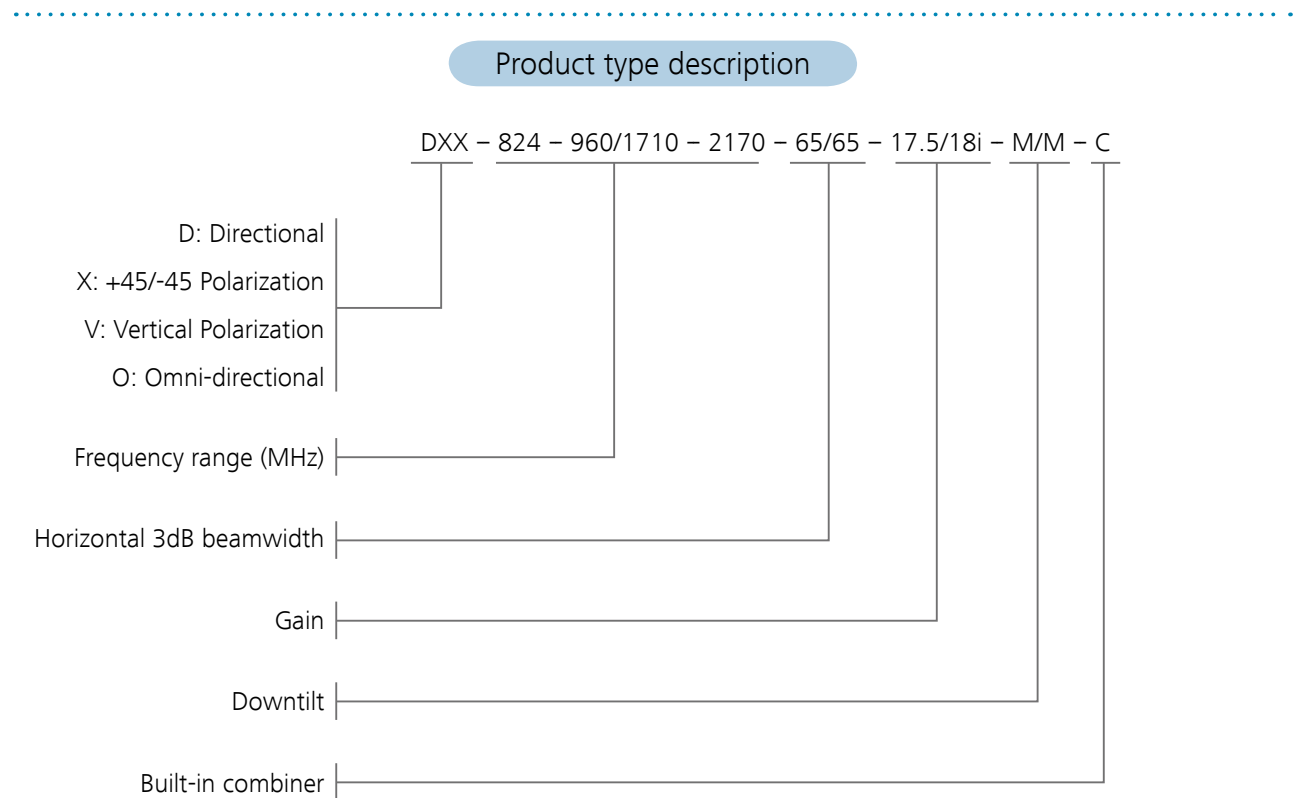

Index

Frequency Range (MHz)	Pol.	Horizontal beam width	Gain (dBi)	Electrical downtilt	Dimensions (H x W x D) (mm)	Page
450-470	+45°/-45°	65°	15	0°, fixed	2042×486×98	5
806-960	+45°/-45°	65°	15	0°, fixed	1322×289×85	6
	+45°/-45°	65°	15	3°, fixed	1322×289×85	7
	+45°/-45°	65°	15	6°, fixed	1322×289×85	8
	+45°/-45°	65°	15.3	0°, fixed	1312×295×126	9
	+45°/-45°	65°	15.3	6°, fixed	1312×295×126	10
	+45°/-45°	65°	15.5	0°-14°, adjustable	1399×289×85	11
	+45°/-45°	65°	17	0°, fixed	1932×289×85	12
	+45°/-45°	65°	17	3°, fixed	1932×289×85	13
	+45°/-45°	65°	17.3	0°, fixed	1972×295×126	14
	+45°/-45°	65°	17.5	2°-9.5°, adjustable	2516×295×95	15
	+45°/-45°	65°	18	0°, fixed	2572×289×85	16
	+45°/-45°	65°	18	3°, fixed	2572×289×85	17
	+45°/-45°	65°	18	6°, fixed	2572×289×85	18
	+45°/-45°	65°	18.2	0°, fixed	2532×295×126	19
	+45°/-45°	65°	18.2	6°, fixed	2532×295×126	20
	+45°/-45°	90°	17	0°, fixed	2526×268×125	21
	+45°/-45°	90°	17	2°-9.5°, adjustable	2526×268×125	22
	890-960	+45°/-45°	65°	18	0°, fixed	2572×289×85
1710-2170	+45°/-45°	33°	21	2°-10°, adjustable	1318×289×85	24
	+45°/-45°	65°	18	0°, fixed	1306×155×79	25
	+45°/-45°	65°	18	2°, fixed	1306×155×79	26
	+45°/-45°	65°	18	3°, fixed	1306×155×79	27
	+45°/-45°	65°	18	6°, fixed	1306×155×79	28
	+45°/-45°	65°	18	2°-10°, adjustable	1306×155×79	29
	+45°/-45°	65°	19.5	2°-8°, adjustable	1940×155×79	30
	+45°/-45°	65°	21	0°, fixed	2170×155×79	31
	+45°/-45°	90°	17	0°, fixed	1190×176×69	32
	+45°/-45°	90°	17	2°, fixed	1190×176×69	33
	+45°/-45°	90°	17	6°, fixed	1190×176×69	34
	+45°/-45°	90°	17	2°-10°, adjustable	1306×155×79	35
	824-960 /1710-2170	+45°/-45°	65°	15/17.5	0°-14°/0°-8°, adjustable	1390×368×99
+45°/-45°		65°	15/18	0°-14°/0°-8°, adjustable	1390×368×99	37
+45°/-45°		65°	16/17.5	0°-8°/0°-8°, adjustable	1925×368×99	38
+45°/-45°		65°	16/18	0°-8°/0°-8°, adjustable	1925×368×99	39
+45°/-45°		65°	17/17.5	0°-8°/0°-8°, adjustable	2449×368×99	40
+45°/-45°		65°	17.5/18	0°-10°/0°-8°, adjustable	2449×368×99	41
1710-2170/1710-2170	+45°/-45°	65°	18/18	2°-10°, adjustable	1306×326×79	42
824-960/1710-2170/ 1710-2170	+45°/-45°	65°	16.5/16.5/16	0°-8°/0°-8°, adjustable	1925×368×99	43
	+45°/-45°	65°	17.5/17.5/17	0°-8°/0°-8°, adjustable	2449×368×99	44

DX-450-470-65-15i-0F

Electrical Properties	
Frequency range (MHz)	450-470
Polarization	±45°
VSWR	≤1.5
Gain (dBi)	15
3dB beamwidth (horizontal)	65°
3dB beamwidth (vertical)	16°
Isolation between ports (dB)	≥30
Front to back ratio (dB)	≥25
Cross polar ratio(dB)	≥15
Electrical downtilt	0°
Intermodulation IM5 (dBc)	≤-160 (2 × 43 dBm carrier)
Max. CW input power (W)	500
Impedance (Ω)	50
Grounding	DC ground

Mechanical Properties	
Dimensions (H×W×D) (mm)	2042×486×98
Packing dimensions (H×W×D) (mm)	2271×596×261
Net weight (kg)	28.3
Bracket weight (kg)	6.5
Packing weight (kg)	42.2
Mechanical downtilt	0° - 16°
Mast diameter (mm)	50 - 115
Radome material	Fiberglass
Operating temperature (°C)	- 55 - + 65
Windload frontal (N)	740(v=150km/h)
Windload lateral (N)	220 (v=150km/h)
Windload rearside (N)	1100 (v=150km/h)
Max. wind velocity (km/h)	200
Connector	2×7/16 DIN Female

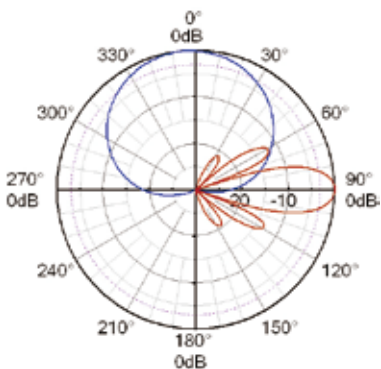
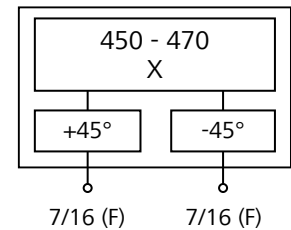

450 - 460 MHz

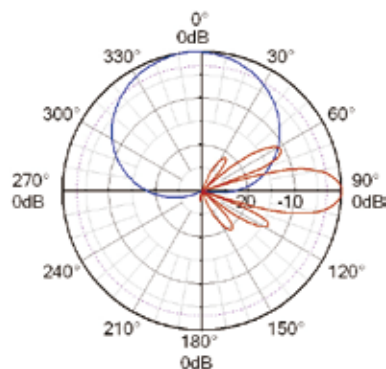

455 - 465 MHz

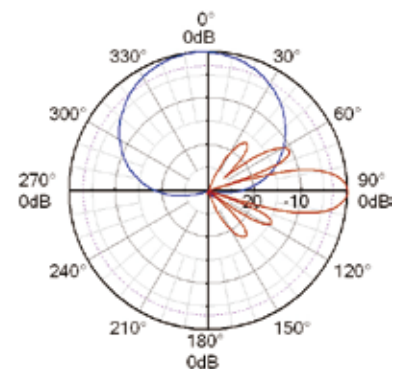

460 - 470 MHz

DX-806-960-65-15i-0F

Electrical Properties			
Frequency range (MHz)	806-866	824-894	880-960
Polarization	±45°		
VSWR	≤1.4		
Gain (dBi)	14.6	14.8	15.0
Side lobe suppression for first side lobe above horizon (dB)	Typ.17	Typ.17	Typ.17
3dB beamwidth (horizontal)	67°	65°	62°
3dB beamwidth (vertical)	15.5°	14.6°	14.0°
Isolation between ports (dB)	≥30		
Front to back ratio (dB)	≥25		
Cross polar ratio(dB)	≥15		
Electrical downtilt	0°		
Intermodulation IM3 (dBc)	≤-150 (2 × 43 dBm carrier)		
Max. CW input power (W)	500		
Impedance (Ω)	50		
Grounding	DC ground		

Mechanical Properties	
Dimensions (H × W × D) (mm)	1322 × 289 × 85
Packing dimensions (H × W × D) (mm)	1662 × 405 × 175
Net weight (kg)	9.5
Bracket weight (kg)	4.6
Packing weight (kg)	18
Mechanical downtilt	0° - 16°
Mast diameter (mm)	50 - 115
Radome material	Fiberglass
Operating temperature (°C)	- 55 - + 65
Windload frontal (N)	290 (v=150km/h)
Windload lateral (N)	130 (v=150km/h)
Windload rearside (N)	430 (v=150km/h)
Max. wind velocity (km/h)	200
Connector	2 × 7/16 DIN Female

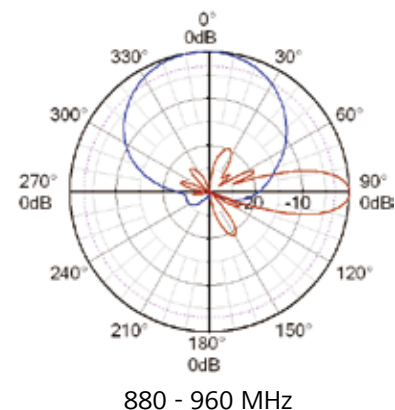
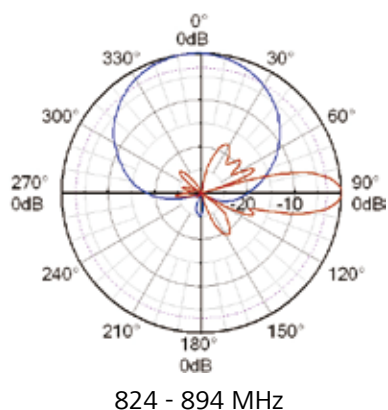
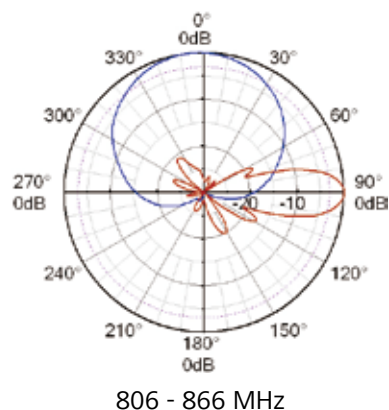
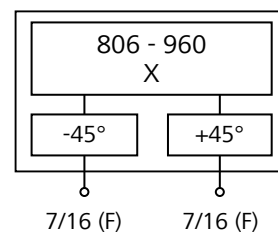

DX-806-960-65-15i-3F

Electrical Properties			
Frequency range (MHz)	806-866	824-894	880-960
Polarization	±45°		
VSWR	≤1.5		
Gain (dBi)	14.7	15.0	15.3
Side lobe suppression for first side lobe above horizon (dB)	Typ.17	Typ.17	Typ.17
3dB beamwidth (horizontal)	67°	65°	62°
3dB beamwidth (vertical)	15.5°	14.6°	14.0°
Isolation between ports (dB)	≥28		
Front to back ratio, (dB)	≥25		
Cross polar ratio(dB)	≥15		
Electrical downtilt	3°		
Intermodulation IM3 (dBC)	≤-150 (2 × 43 dBm carrier)		
Max. CW input power (W)	500		
Impedance (Ω)	50		
Grounding	DC ground		

Mechanical Properties	
Dimensions (H × W × D) (mm)	1322 × 289 × 85
Packing dimensions (H × W × D) (mm)	1662 × 405 × 175
Net weight (kg)	9.5
Bracket weight (kg)	4.6
Packing weight (kg)	18
Mechanical downtilt	0° - 16°
Mast diameter (mm)	50 - 115
Radome material	Fiberglass
Operating temperature (°C)	- 55 - + 65
Windload frontal (N)	290 (v=150km/h)
Windload lateral (N)	130 (v=150km/h)
Windload rearside (N)	430 (v=150km/h)
Max. wind velocity (km/h)	200
Connector	2 × 7/16 DIN Female

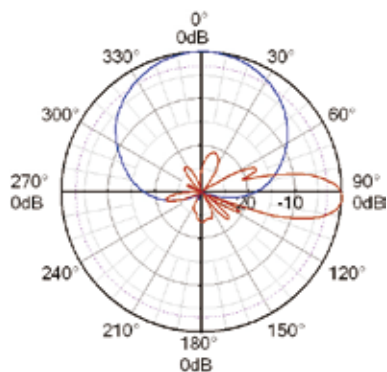
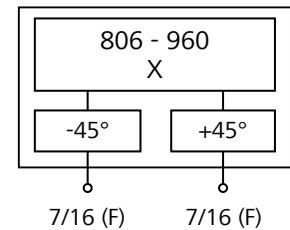

806 - 866 MHz

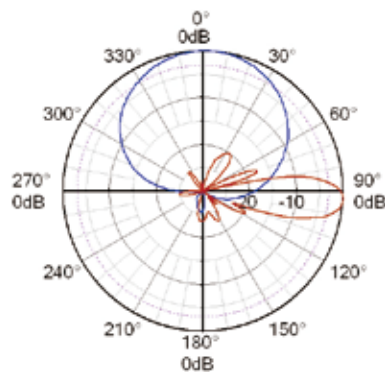

824 - 894 MHz

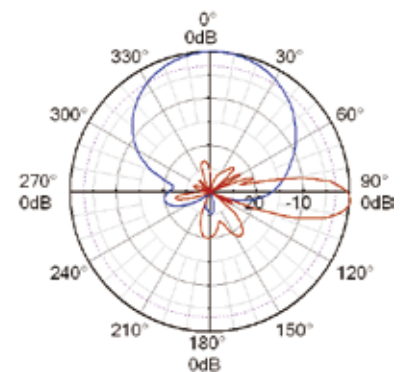

880 - 960 MHz

DX-806-960-65-15i-6F

Electrical Properties			
Frequency range (MHz)	806-866	824-894	880-960
Polarization	±45°		
VSWR	≤1.4		
Gain (dBi)	14.5	14.7	14.9
Side lobe suppression for first side lobe above horizon (dB)	Typ.17	Typ.17	Typ.17
3dB beamwidth (horizontal)	67°	65°	62°
3dB beamwidth (vertical)	15.5°	14.9°	14.0°
Isolation between ports (dB)	≥30		
Front to back ratio (dB)	≥25		
Cross polar ratio(dB)	≥15		
Electrical downtilt	6°		
Intermodulation IM3 (dBc)	≤-150 (2 × 43 dBm carrier)		
Max. CW input power (W)	500		
Impedance (Ω)	50		
Grounding	DC ground		

Mechanical Properties	
Dimensions (H × W × D) (mm)	1322 × 289 × 85
Packing dimensions (H × W × D) (mm)	1662 × 405 × 175
Net weight (kg)	9.5
Bracket weight (kg)	4.6
Packing weight (kg)	18
Mechanical downtilt	0° - 16°
Mast diameter (mm)	50 - 115
Radome material	Fiberglass
Operating temperature (°C)	- 55 - + 65
Windload frontal (N)	290 (v=150km/h)
Windload lateral (N)	130 (v=150km/h)
Windload rearside (N)	430 (v=150km/h)
Max. wind velocity (km/h)	200
Connector	2 × 7/16 DIN Female

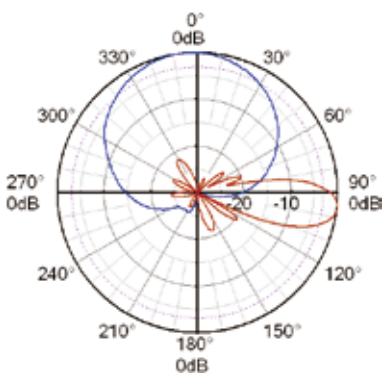
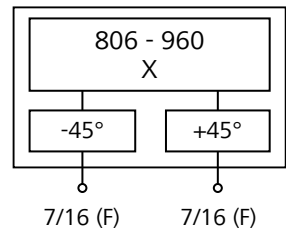

806 - 866 MHz

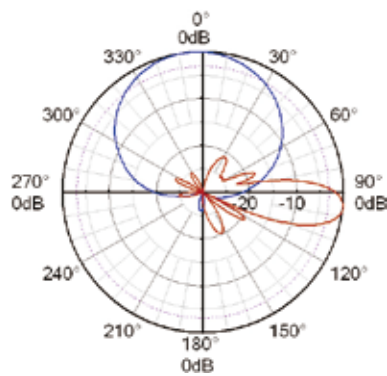

824 - 894 MHz

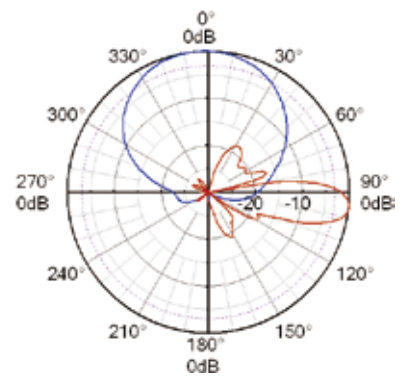

880 - 960 MHz

DX-806-960-65-15.3i-0F

Electrical Properties			
Frequency range (MHz)	806-866	824-894	880-960
Polarization	±45°		
VSWR	≤1.4	≤1.4	≤1.3
Gain (dBi)	14.8	15.0	15.3
Side lobe suppression for first side lobe above horizon (dB)	≥19	≥19	≥19
3dB beamwidth (horizontal)	68°	66°	64°
3dB beamwidth (vertical)	15.9°	15.4°	14.3°
Isolation between ports (dB)	≥30		
Front to back ratio (dB)	≥30		
Cross polar ratio(dB)	0°	≥20	
	±60°	≥10	
Electrical downtilt	0°		
Intermodulation IM3 (dBC)	≤-150 (2 × 43 dBm carrier)		
Max. CW input power (W)	500		
Impedance (Ω)	50		
Grounding	DC ground		

Mechanical Properties	
Dimensions (H × W × D) (mm)	1312 × 295 × 126
Packing dimensions (H × W × D) (mm)	1622 × 405 × 205
Net weight (kg)	10.5
Bracket weight (kg)	4.6
Packing weight (kg)	18
Mechanical downtilt	0° - 16°
Mast diameter (mm)	50 - 115
Radome material	Fiberglass
Operating temperature (°C)	- 55 - + 65
Windload frontal (N)	290 (v=150km/h)
Windload lateral (N)	190 (v=150km/h)
Windload rearside (N)	430 (v=150km/h)
Max. wind velocity (km/h)	200
Connector	2x7/16 DIN Female

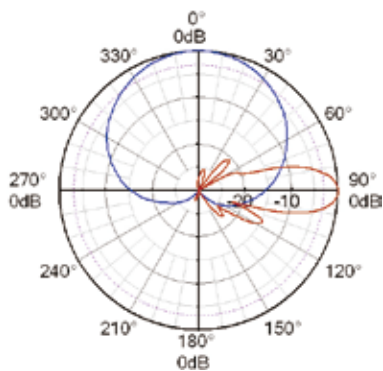
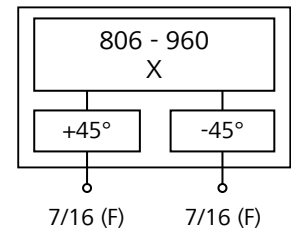

806 - 866 MHz

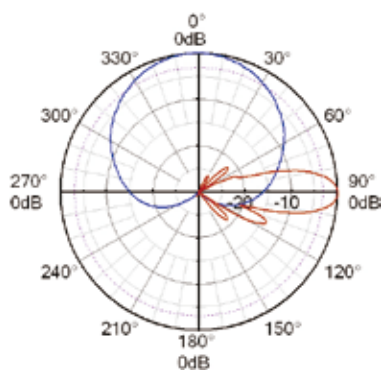

824 - 894 MHz

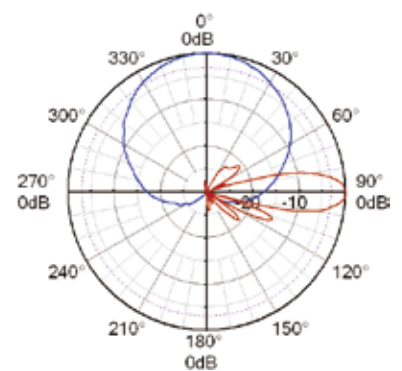

880 - 960 MHz

DX-806-960-65-15.3i-6F

Electrical Properties			
Frequency range (MHz)	806-866	824-894	880-960
Polarization	±45°		
VSWR	≤1.35	≤1.35	≤1.3
Gain (dBi)	14.7	14.9	15.2
Side lobe suppression for first side lobe above horizon (dB)	≥19	≥19	≥19
3dB beamwidth (horizontal)	68°	66°	64°
3dB beamwidth (vertical)	15.9°	15.4°	14.3°
Isolation between ports (dB)	≥30		
Front to back ratio (dB)	≥30		
Cross polar ratio(dB)	0°	≥20	
	±60°	≥10	
Electrical downtilt	6°		
Intermodulation IM3 (dBC)	≤-150 (2 × 43 dBm carrier)		
Max. CW input power (W)	500		
Impedance (Ω)	50		
Grounding	DC ground		

Mechanical Properties	
Dimensions (H × W × D) (mm)	1312 × 295 × 126
Packing dimensions (H × W × D) (mm)	1622 × 405 × 205
Net weight (kg)	10.5
Bracket weight (kg)	4.6
Packing weight (kg)	18
Mechanical downtilt	0° - 16°
Mast diameter (mm)	50 - 115
Radome material	Fiberglass
Operating temperature (°C)	- 55 - + 65
Windload frontal (N)	290 (v=150km/h)
Windload lateral (N)	190 (v=150km/h)
Windload rear side (N)	430 (v=150km/h)
Max. wind velocity (km/h)	200
Connector	2×7/16 DIN Female

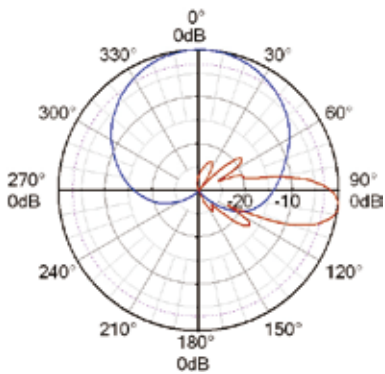
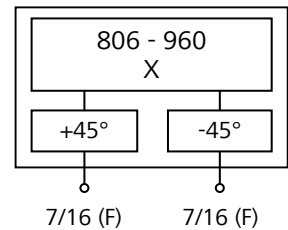

806 - 866 MHz

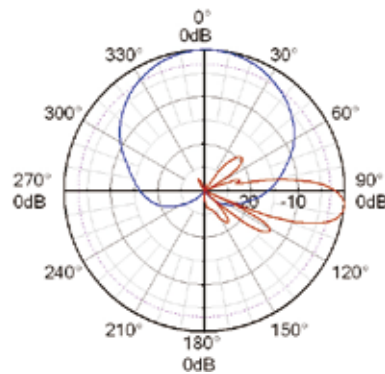

824 - 894 MHz

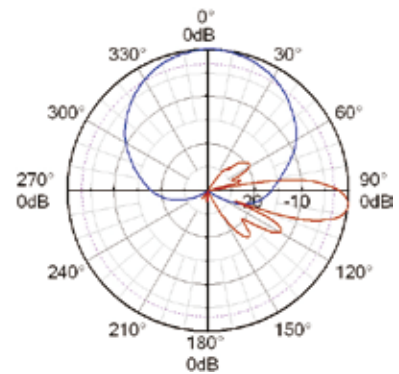

880 - 960 MHz

DX-806-960-65-15.5i-M

Electrical Properties										
Frequency range (MHz)	806-866			824-894			880-960			
Polarization	±45°									
VSWR	≤1.5			≤1.45			≤1.45			
Gain (dBi)	(°)	0	7	14	0	7	14	0	7	14
	(dB)	15.0	14.8	14.6	15.3	15.2	15.0	15.5	15.3	15.1
Side lobe suppression for first side lobe above horizon (dB)	(°)	0	7	14	0	7	14	0	7	14
	(dB)	18	17	16	18	17	16	18	17	16
3dB beamwidth (horizontal)	68°			66°			65°			
3dB beamwidth (vertical)	14.5°			14.0°			13.5°			
Isolation between portsw (dB)	≥30									
Front to back ratio (dB)	≥28									
Cross polar ratio(dB)	0°	≥18								
	±60°	≥10								
Electrical downtilt	0°-14°									
Intermodulation IM3 (dBc)	≤-150 (2 × 43 dBm carrier)									
Max. CW input power (W)	500									
Impedance (Ω)	50									
Grounding	DC ground									



Mechanical Properties	
Dimensions (H × W × D) (mm)	1399 × 289 × 85
Packing dimensions (H × W × D) (mm)	1740 × 405 × 175
Net weight (kg)	11.5
Bracket weight (kg)	4.6
Packing weight (kg)	20
Mechanical downtilt	0° - 16°
Mast diameter (mm)	50 - 115
Radome material	Fiberglass
Operating temperature (°C)	- 55 - + 65
Windload frontal (N)	290 (v=150km/h)
Windload lateral (N)	130 (v=150km/h)
Windload rearside (N)	430 (v=150km/h)
Max. wind velocity (km/h)	200
Connector	2×7/16 DIN Female

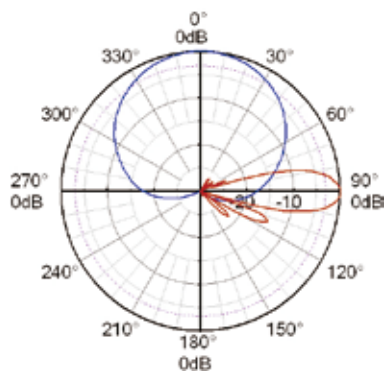
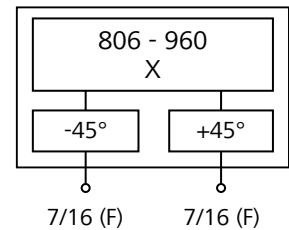

806 - 866 MHz

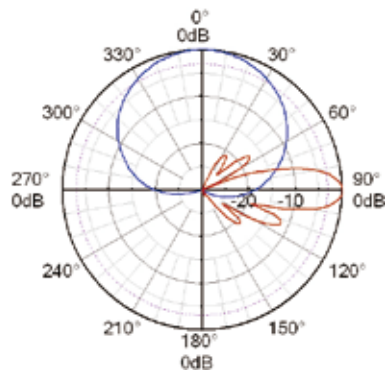

824 - 894 MHz

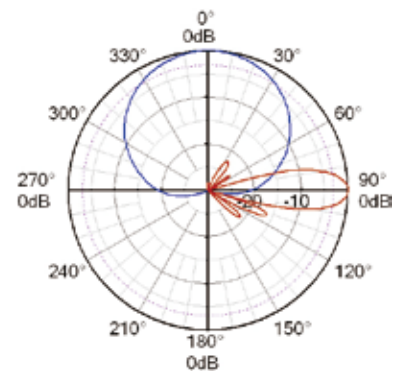

880 - 960 MHz

DX-806-960-65-17i-0F

Electrical Properties			
Frequency range (MHz)	806-866	824-894	880-960
Polarization	±45°		
VSWR	≤1.37		
Gain (dBi)	16.6	16.8	17.0
Side lobe suppression for first side lobe above horizon (dB)	Typ.17	Typ.17	Typ.17
3dB beamwidth (horizontal)	67°	64°	63°
3dB beamwidth (vertical)	11.0°	10.5°	10.0°
Isolation between ports (dB)	≥28		
Front to back ratio (dB)	≥25		
Cross polar ratio(dB)	≥15		
Electrical downtilt	0°		
Intermodulation IM3 (dBc)	≤-150 (2 × 43 dBm carrier)		
Max. CW input power (W)	500		
Impedance (Ω)	50		
Grounding	DC ground		

Mechanical Properties	
Dimensions (H × W × D) (mm)	1932 × 289 × 85
Packing dimensions (H × W × D) (mm)	2272 × 405 × 175
Net weight (kg)	13.5
Bracket weight (kg)	4.6
Packing weight (kg)	22
Mechanical downtilt	0° - 12°
Mast diameter (mm)	50 - 115
Radome material	Fiberglass
Operating temperature (°C)	- 55 - + 65
Windload frontal (N)	420 (v=150km/h)
Windload lateral (N)	190 (v=150km/h)
Windload rearside (N)	620 (v=150km/h)
Max. wind velocity (km/h)	200
Connector	2×7/16 DIN Female

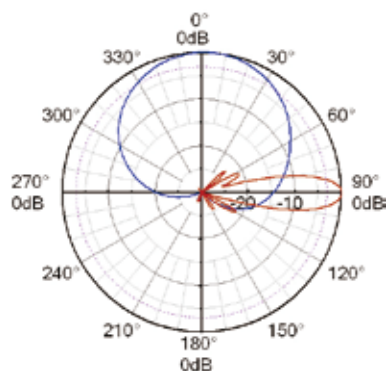
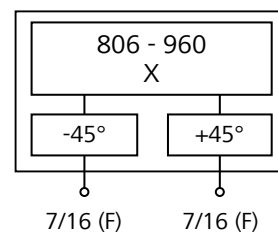

806 - 866 MHz

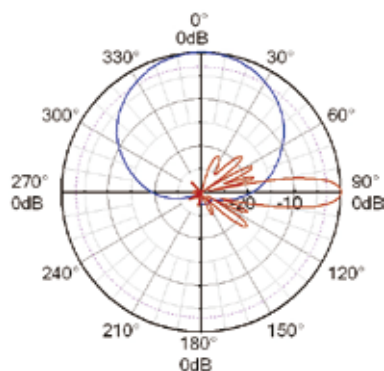

824 - 894 MHz

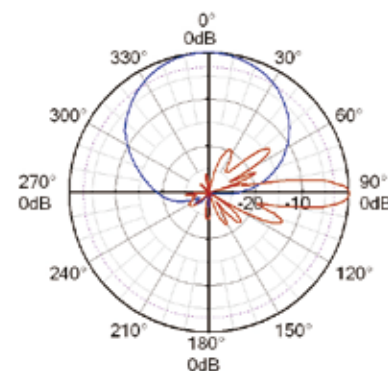

880 - 960 MHz

DX-806-960-65-17i-3F

Electrical Properties			
Frequency range (MHz)	806-866	824-894	880-960
Polarization	±45°		
VSWR	≤1.5		
Gain (dBi)	16.7	17.0	17.2
Side lobe suppression for first side lobe above horizon (dB)	Typ.17	Typ.17	Typ.17
3dB beamwidth (horizontal)	67°	64°	63°
3dB beamwidth (vertical)	11.0°	10.5°	10.0°
Isolation between ports (dB)	≥28		
Front to back ratio (dB)	≥25		
Cross polar ratio(dB)	≥15		
Electrical downtilt	3°		
Intermodulation IM3 (dBC)	≤-150 (2 × 43 dBm carrier)		
Max. CW input power (W)	500		
Impedance (Ω)	50		
Grounding	DC ground		

Mechanical Properties	
Dimensions (H × W × D) (mm)	1932 × 289 × 85
Packing dimensions (H × W × D) (mm)	2272 × 405 × 175
Net weight (kg)	13.5
Bracket weight (kg)	4.6
Packing weight (kg)	22
Mechanical downtilt	0° - 12°
Mast diameter (mm)	50 - 115
Radome material	Fiberglass
Operating temperature (°C)	- 55 - + 65
Windload frontal (N)	420 (v=150km/h)
Windload lateral (N)	190 (v=150km/h)
Windload rearside (N)	620 (v=150km/h)
Max. wind velocity (km/h)	200
Connector	2×7/16 DIN Female

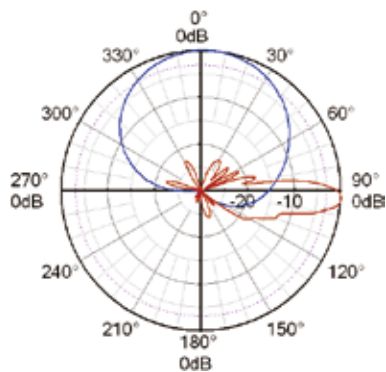
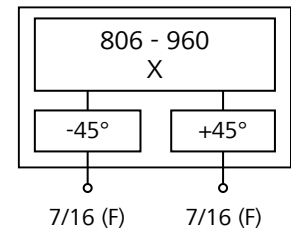

806 - 866 MHz

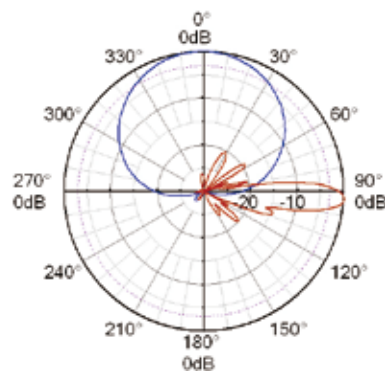

824 - 894 MHz

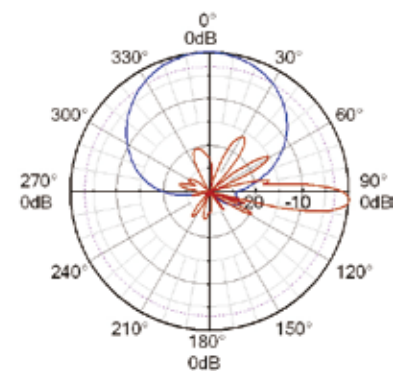

880 - 960 MHz

DX-806-960-65-17.3i-0F

Electrical Properties			
Frequency range (MHz)	806-866	824-894	880-960
Polarization	±45°		
VSWR	≤1.4	≤1.4	≤1.3
Gain (dBi)	16.8	17.0	17.3
Side lobe suppression for first side lobe above horizon (dB)	≥19	≥19	≥19
3dB beamwidth (horizontal)	68°	66°	64°
3dB beamwidth (vertical)	10.6°	10.2°	9.5°
Isolation between ports (dB)	≥30		
Front to back ratio (dB)	≥30		
Cross polar ratio(dB)	0°	≥20	
	±60°	≥10	
Electrical downtilt	0°		
Intermodulation IM3 (dBC)	≤-150 (2 × 43 dBm carrier)		
Max. CW input power (W)	500		
Impedance (Ω)	50		
Grounding	DC ground		

Mechanical Properties	
Dimensions (H × W × D) (mm)	1972 × 295 × 126
Packing dimensions (H × W × D) (mm)	2282 × 405 × 205
Net weight (kg)	14.5
Bracket weight (kg)	4.6
Packing weight (kg)	24
Mechanical downtilt	0° - 12°
Mast diameter (mm)	50 - 115
Radome material	Fiberglass
Operating temperature (°C)	- 55 - + 65
Windload frontal (N)	440 (v=150km/h)
Windload lateral (N)	280 (v=150km/h)
Windload rearside (N)	650 (v=150km/h)
Max. wind velocity (km/h)	200
Connector	2×7/16 DIN Female

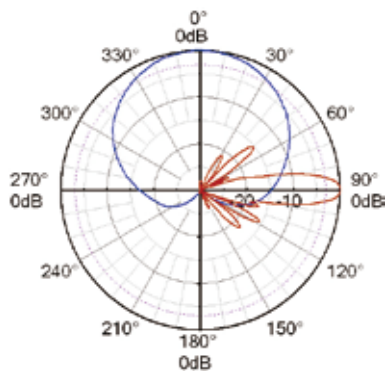
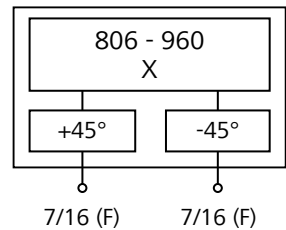

806 - 866 MHz

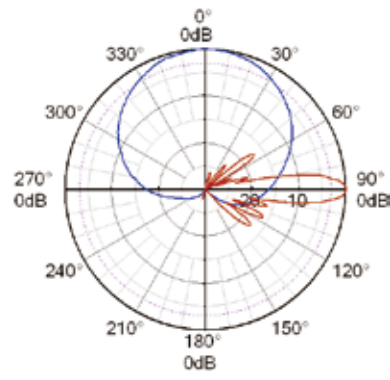

824 - 894 MHz

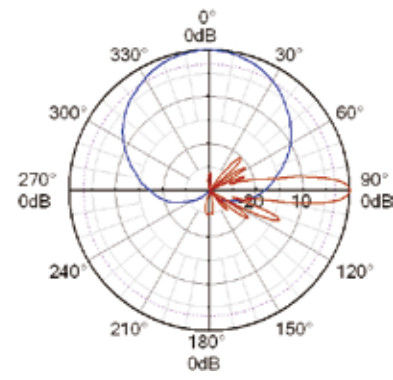

880 - 960 MHz

DX-806-960-65-17.5i-M

Electrical Properties										
Frequency range (MHz)	806-866			824-894			880-960			
Polarization	±45°									
VSWR	≤1.47			≤1.4			≤1.4			
Gain (dBi)	(°)	2	6	9.5	2	6	9.5	2	6	9.5
	(dB)	17.1	17.2	16.9	17.2	17.3	17.0	17.4	17.5	17.2
Side lobe suppression for first side lobe above horizon (dB)	(°)	2	6	9.5	2	6	9.5	2	6	9.5
	(dB)	18	17	16	18	17	16	18	17	16
3dB beamwidth (horizontal)	68°			66°			65°			
3dB beamwidth (vertical)	8.8°			8.5°			7.8°			
Isolation between portsw (dB)	≥30									
Front to back ratio (dB)	≥28									
Cross polar ratio(dB)	0°	≥18								
	±60°	≥10								
Electrical downtilt	2°-9.5°									
Intermodulation IM3 (dBc)	≤-150 (2 × 43 dBm carrier)									
Max. CW input power (W)	500									
Impedance (Ω)	50									
Grounding	DC ground									



Mechanical Properties	
Dimensions (H × W × D) (mm)	2516 × 295 × 95
Packing dimensions (H × W × D) (mm)	2855 × 405 × 175
Net weight (kg)	15.5
Bracket weight (kg)	5.5
Packing weight (kg)	27
Mechanical downtilt	0° - 8°
Mast diameter (mm)	50 - 115
Radome material	Fiberglass
Operating temperature (°C)	- 55 - + 65
Windload frontal (N)	960 (v=150km/h)
Windload lateral (N)	360 (v=150km/h)
Windload rearside (N)	960 (v=150km/h)
Max. wind velocity (km/h)	200
Connector	2×7/16 DIN Female

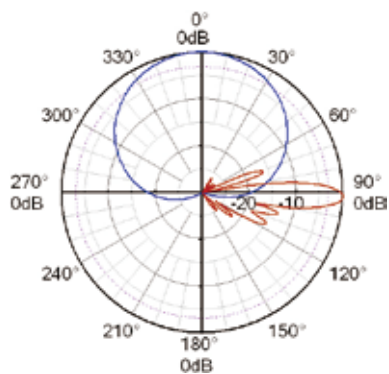
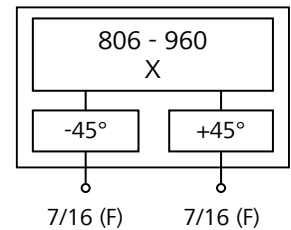

806 - 866 MHz

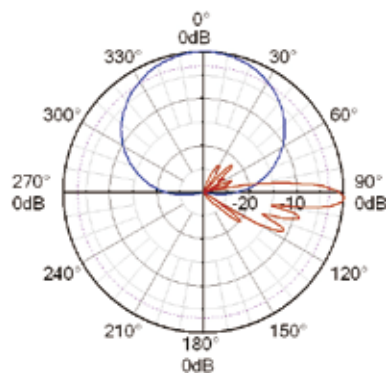

824 - 894 MHz

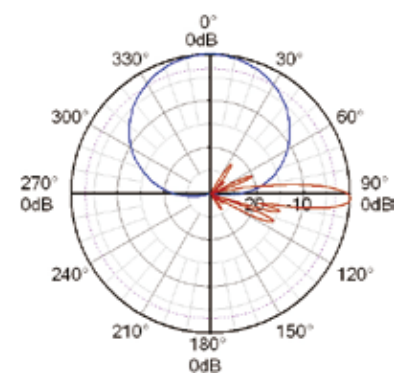

880 - 960 MHz

DX-806-960-65-18i-0F

Electrical Properties			
Frequency range (MHz)	806-866	824-894	880-960
Polarization	±45°		
VSWR	≤1.45		
Gain (dBi)	17.4	17.6	17.8
Side lobe suppression for first side lobe above horizon (dB)	Typ.17	Typ.17	Typ.17
3dB beamwidth (horizontal)	67°	64°	63°
3dB beamwidth (vertical)	8.2°	7.5°	7.0°
Isolation between ports (dB)	≥28		
Front to back ratio (dB)	≥25		
Cross polar ratio(dB)	≥15		
Electrical downtilt	0°		
Intermodulation IM3 (dBc)	≤-150 (2 × 43 dBm carrier)		
Max. CW input power (W)	500		
Impedance (Ω)	50		
Grounding	DC ground		

Mechanical Properties	
Dimensions (H × W × D) (mm)	2572 × 289 × 85
Packing dimensions (H × W × D) (mm)	2912 × 405 × 175
Net weight (kg)	16.5
Bracket weight (kg)	4.6
Packing weight (kg)	26
Mechanical downtilt	0° - 8°
Mast diameter (mm)	50 - 115
Radome material	Fiberglass
Operating temperature (°C)	- 55 - + 65
Windload frontal (N)	560 (v=150km/h)
Windload lateral (N)	240 (v=150km/h)
Windload rearside (N)	830 (v=150km/h)
Max. wind velocity (km/h)	200
Connector	2×7/16 DIN Female

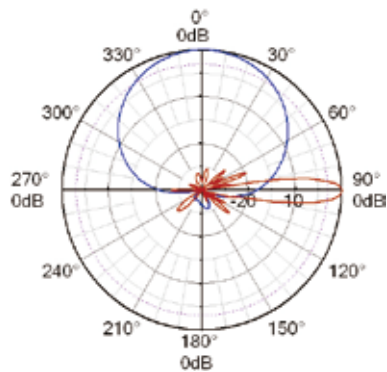
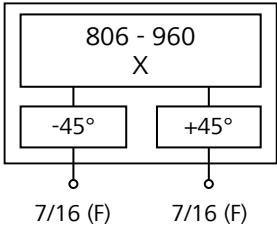

806 - 866 MHz

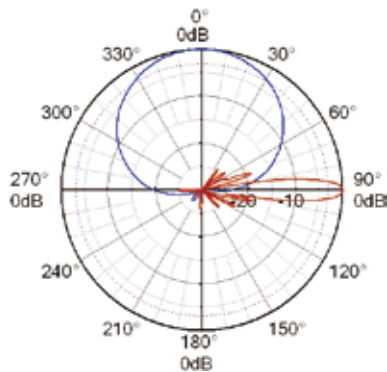

824 - 894 MHz

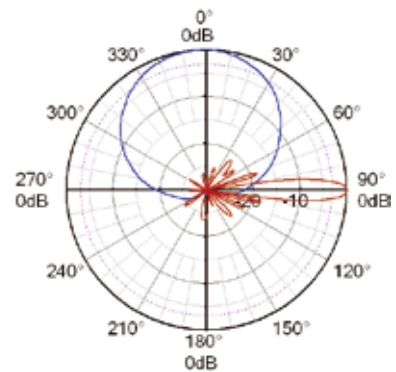

880 - 960 MHz

DX-806-960-65-18i-3F

Electrical Properties			
Frequency range (MHz)	806-866	824-894	880-960
Polarization	±45°		
VSWR	≤1.45		
Gain (dBi)	17.8	18.0	18.2
Side lobe suppression for first side lobe above horizon (dB)	Typ.17	Typ.17	Typ.17
3dB beamwidth (horizontal)	67°	64°	63°
3dB beamwidth (vertical)	8.2°	7.5°	7.0°
Isolation between ports (dB)	≥28		
Front to back ratio (dB)	≥25		
Cross polar ratio(dB)	≥15		
Electrical downtilt	3°		
Intermodulation IM3 (dBC)	≤-150 (2 × 43 dBm carrier)		
Max. CW input power (W)	500		
Impedance (Ω)	50		
Grounding	DC ground		

Mechanical Properties	
Dimensions (H × W × D) (mm)	2572 × 289 × 85
Packing dimensions (H × W × D) (mm)	2912 × 405 × 175
Net weight (kg)	16.5
Bracket weight (kg)	4.6
Packing weight (kg)	26
Mechanical downtilt	0° - 8°
Mast diameter (mm)	50 - 115
Radome material	Fiberglass
Operating temperature (°C)	- 55 - + 65
Windload frontal (N)	560 (v=150km/h)
Windload lateral (N)	240 (v=150km/h)
Windload rearside (N)	830 (v=150km/h)
Max. wind velocity (km/h)	200
Connector	2×7/16 DIN Female

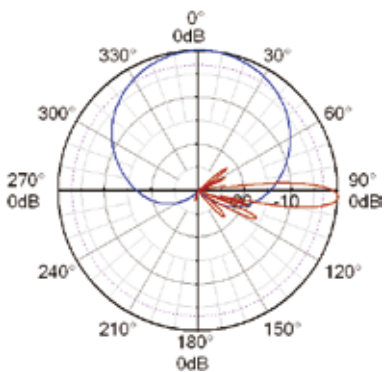
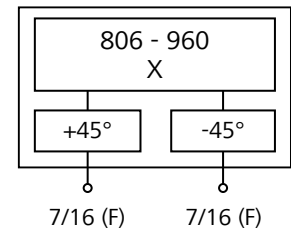

806 - 866 MHz

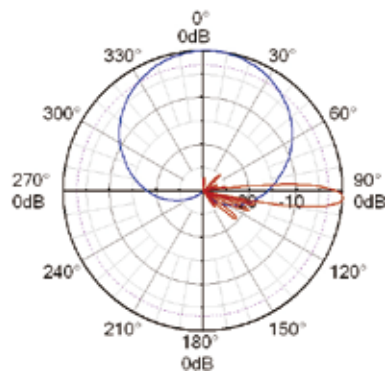

824 - 894 MHz

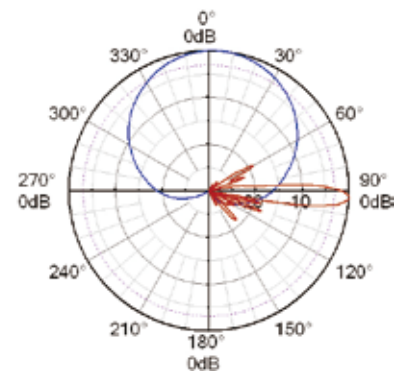

880 - 960 MHz

DX-806-960-65-18i-6F

Electrical Properties			
Frequency range (MHz)	806-866	824-894	880-960
Polarization	±45°		
VSWR	≤1.37		
Gain (dBi)	17.3	17.6	17.8
Side lobe suppression for first side lobe above horizon (dB)	Typ.17	Typ.17	Typ.17
3dB beamwidth (horizontal)	67°	64°	63°
3dB beamwidth (vertical)	8.0°	7.3°	6.8°
Isolation between ports (dB)	≥30		
Front to back ratio (dB)	≥25		
Cross polar ratio(dB)	≥15		
Electrical downtilt	6°		
Intermodulation IM3 (dBc)	≤-150 (2 × 43 dBm carrier)		
Max. CW input power (W)	500		
Impedance (Ω)	50		
Grounding	DC ground		

Mechanical Properties	
Dimensions (H × W × D) (mm)	2572 × 289 × 85
Packing dimensions (H × W × D) (mm)	2912 × 405 × 175
Net weight (kg)	16.5
Bracket weight (kg)	4.6
Packing weight (kg)	26
Mechanical downtilt	0° - 8°
Mast diameter (mm)	50 - 115
Radome material	Fiberglass
Operating temperature (°C)	- 55 - + 65
Windload frontal (N)	560 (v=150km/h)
Windload lateral (N)	240 (v=150km/h)
Windload rearside (N)	830 (v=150km/h)
Max. wind velocity (km/h)	200
Connector	2×7/16 DIN Female

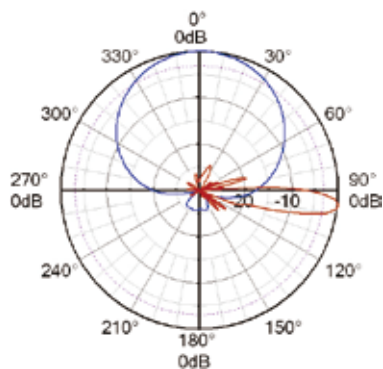
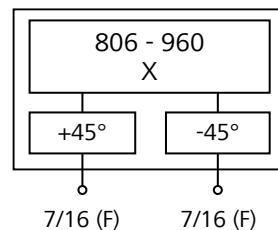

806 - 866 MHz

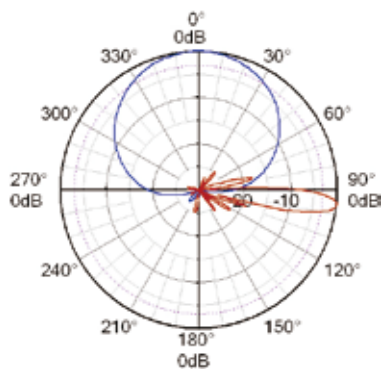

824 - 894 MHz

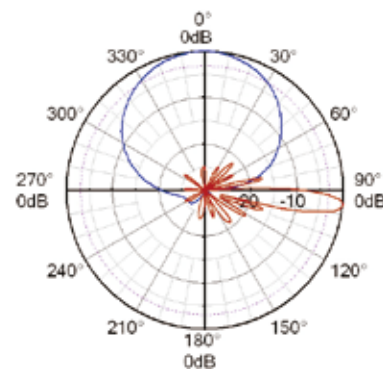

880 - 960 MHz

DX-806-960-65-18.2i-0F

Electrical Properties			
Frequency range (MHz)	806-866	824-894	880-960
Polarization	±45°		
VSWR	≤1.4	≤1.4	≤1.3
Gain (dBi)	17.8	18.0	18.2
Side lobe suppression for first side lobe above horizon (dB)	≥18	≥18	≥18
3dB beamwidth (horizontal)	68°	66°	64°
3dB beamwidth (vertical)	8.0°	7.8°	7.3°
Isolation between ports (dB)	≥30		
Front to back ratio (dB)	≥30		
Cross polar ratio(dB)	0°	≥20	
	±60°	≥10	
Electrical downtilt	0°		
Intermodulation IM3 (dBC)	≤-150 (2 × 43 dBm carrier)		
Max. CW input power (W)	500		
Impedance (Ω)	50		
Grounding	DC ground		

Mechanical Properties	
Dimensions (H × W × D) (mm)	2532 × 295 × 126
Packing dimensions (H × W × D) (mm)	2842 × 405 × 205
Net weight (kg)	19
Bracket weight (kg)	4.6
Packing weight (kg)	28
Mechanical downtilt	0° - 8°
Mast diameter (mm)	50 - 115
Radome material	Fiberglass
Operating temperature (°C)	- 55 - + 65
Windload frontal (N)	560 (v=150km/h)
Windload lateral (N)	360 (v=150km/h)
Windload rearside (N)	830 (v=150km/h)
Max. wind velocity (km/h)	200
Connector	2×7/16 DIN Female

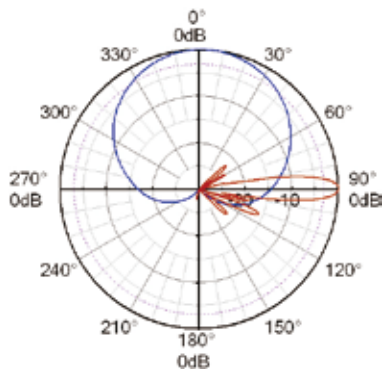
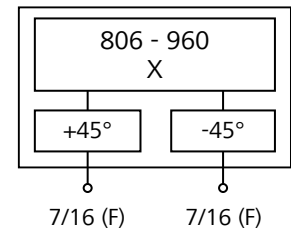

806 - 866 MHz

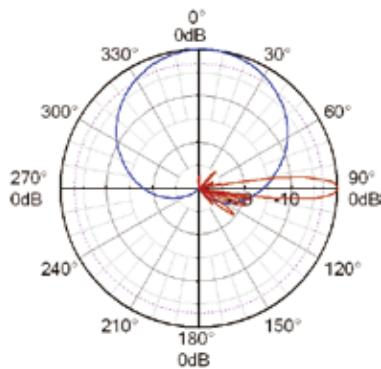

824 - 894 MHz

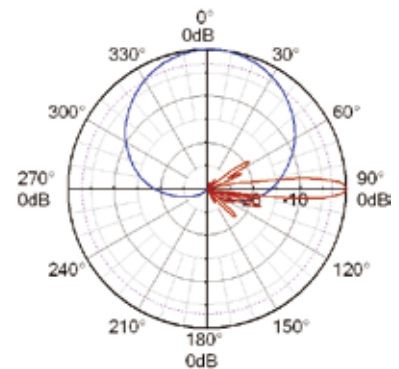

880 - 960 MHz

DX-806-960-65-18.2i-6F

Electrical Properties			
Frequency range (MHz)	806-866	824-894	880-960
Polarization	±45°		
VSWR	≤1.4	≤1.4	≤1.3
Gain (dBi)	17.5	17.7	18.0
Side lobe suppression for first side lobe above horizon (dB)	≥19	≥19	≥19
3dB beamwidth (horizontal)	68°	66°	64°
3dB beamwidth (vertical)	8.0°	7.8°	7.3°
Isolation between ports (dB)	≥32		
Front to back ratio (dB)	≥30		
Cross polar ratio(dB)	0°	≥20	
	±60°	≥10	
Electrical downtilt	6°		
Intermodulation IM3 (dBC)	≤-150 (2 × 43 dBm carrier)		
Max. CW input power (W)	500		
Impedance (Ω)	50		
Grounding	DC ground		

Mechanical Properties	
Dimensions (H × W × D) (mm)	2532 × 295 × 126
Packing dimensions (H × W × D) (mm)	2842 × 405 × 205
Net weight (kg)	19
Bracket weight (kg)	4.6
Packing weight (kg)	28
Mechanical downtilt	0° - 8°
Mast diameter (mm)	50 - 115
Radome material	Fiberglass
Operating temperature (°C)	- 55 - + 65
Windload frontal (N)	560 (v=150km/h)
Windload lateral (N)	360 (v=150km/h)
Windload rearside (N)	830 (v=150km/h)
Max. wind velocity (km/h)	200
Connector	2×7/16 DIN Female

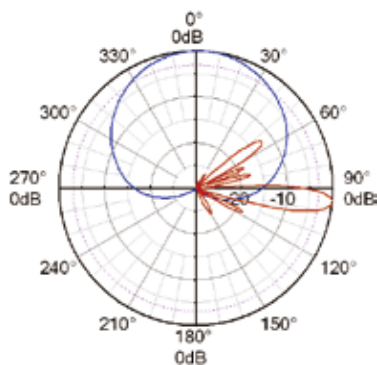
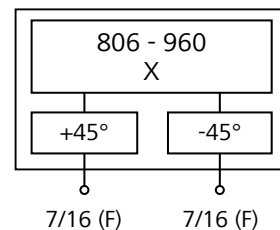

806 - 866 MHz

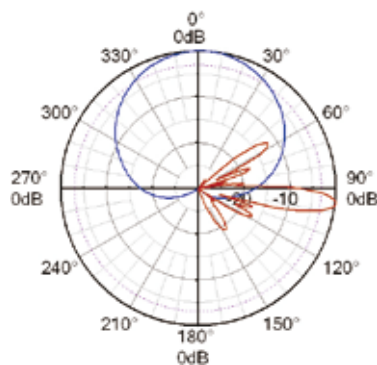

824 - 894 MHz

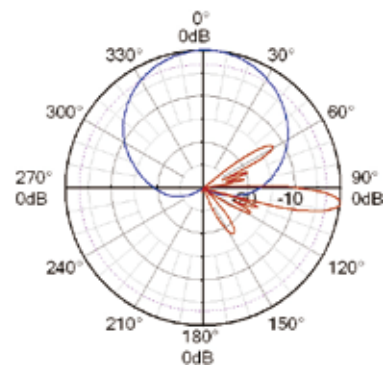

880 - 960 MHz

DX-806-960-90-17i-0F

Single-band Antennas

Electrical Properties			
Frequency range (MHz)	806-866	824-894	880-960
Polarization	±45°		
VSWR	≤1.4	≤1.4	≤1.4
Gain (dBi)	16.5	16.8	17.0
Side lobe suppression for first side lobe above horizon (dB)	≥18	≥18	≥18
3dB beamwidth (horizontal)	88°	86°	84°
3dB beamwidth (vertical)	8.1°	7.9°	7.2°
Isolation between ports (dB)	≥30		
Front to back ratio (dB)	≥25		
Cross polar ratio(dB)	0°	≥15	
	±60°	≥10	
Electrical downtilt	0°		
Intermodulation IM3 (dBC)	≤-150 (2 × 43 dBm carrier)		
Max. CW input power (W)	500		
Impedance (Ω)	50		
Grounding	DC ground		

Mechanical Properties	
Dimensions (H × W × D) (mm)	2526 × 268 × 125
Packing dimensions (H × W × D) (mm)	2842 × 405 × 205
Net weight (kg)	19
Bracket weight (kg)	4.6
Packing weight (kg)	26
Mechanical downtilt	0° - 8°
Mast diameter (mm)	50 - 115
Radome material	Fiberglass
Operating temperature (°C)	- 55 - + 65
Windload frontal (N)	510 (v=150km/h)
Windload lateral (N)	350 (v=150km/h)
Windload rearside (N)	750 (v=150km/h)
Max. wind velocity (km/h)	200
Connector	2×7/16 DIN Female

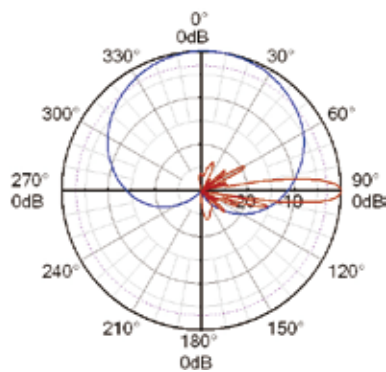
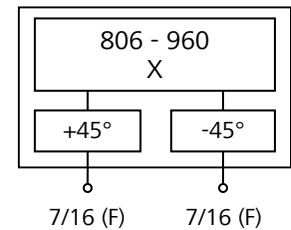

806 - 866 MHz

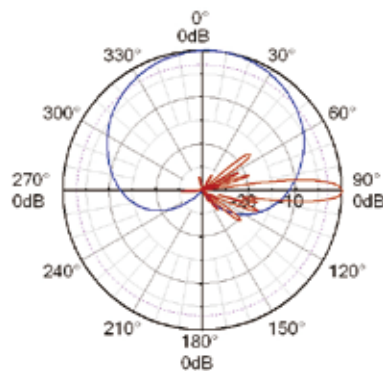

824 - 894 MHz

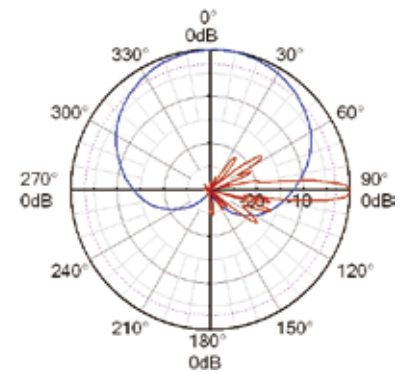

880 - 960 MHz

DX-806-960-90-17i-M

Electrical Properties										
Frequency range (MHz)	806-866			824-894			880-960			
Polarization	±45°									
VSWR	≤1.45			≤1.4			≤1.4			
Gain (dBi)	(°)	2	6	9.5	2	6	9.5	2	6	9.5
	(dB)	16.1	16.2	16	16.3	16.4	16.2	16.4	16.5	16.3
Side lobe suppression for first side lobe above horizon (dB)	(°)	2	6	9.5	2	6	9.5	2	6	9.5
	(dB)	18	18	18	18	18	18	18	18	18
3dB beamwidth (horizontal)	88°			86°			85°			
3dB beamwidth (vertical)	8.2°			7.6°			7.4°			
Isolation between portsw (dB)	≥30									
Front to back ratio (dB)	≥25									
Cross polar ratio(dB)	0°	≥20								
	±60°	Typ. 13								
Electrical downtilt	2° - 9.5°									
Intermodulation IM3 (dBc)	≤-150 (2 × 43 dBm carrier)									
Max. CW input power (W)	500									
Impedance (Ω)	50									
Grounding	DC ground									

Mechanical Properties	
Dimensions (H × W × D) (mm)	2526 × 268 × 125
Packing dimensions (H × W × D) (mm)	2842 × 405 × 205
Net weight (kg)	18.6
Bracket weight (kg)	4.6
Packing weight (kg)	27
Mechanical downtilt	0° - 8°
Mast diameter (mm)	50 - 115
Radome material	Fiberglass
Operating temperature (°C)	- 55 - + 65
Windload frontal (N)	510 (v=150km/h)
Windload lateral (N)	350 (v=150km/h)
Windload rearside (N)	750 (v=150km/h)
Max. wind velocity (km/h)	200
Connector	2×7/16 DIN Female

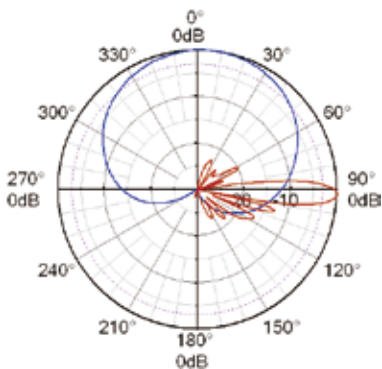
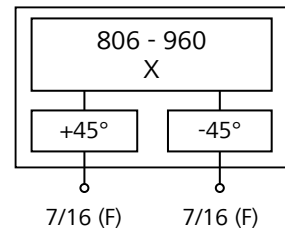

806 - 866 MHz

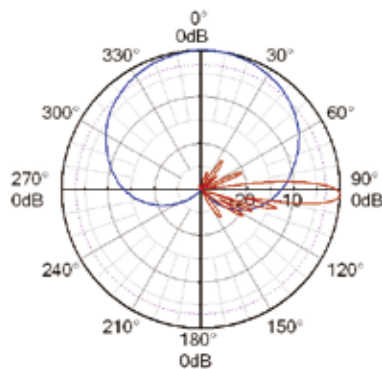

824 - 894 MHz

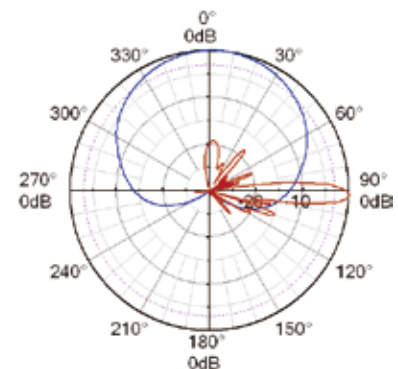

880 - 960 MHz

DX-890-960-65-18i-0F

Electrical Properties	
Frequency range (MHz)	890-960
Polarization	±45°
VSWR	≤1.3
Gain (dBi)	18
Side lobe suppression for first side lobe above horizon (dB)	≥18
3dB beamwidth (horizontal)	65°
3dB beamwidth (vertical)	7°
Isolation between ports (dB)	≥30
Front to back ratio (dB)	≥25
Cross polar ratio(dB)	≥15
Electrical downtilt	0°
Intermodulation IM3 (dBc)	≤-150 (2 × 43 dBm carrier)
Max. CW input power (W)	500
Impedance (Ω)	50
Grounding	DC ground

Mechanical Properties	
Dimensions (H × W × D) (mm)	2572 × 289 × 85
Packing dimensions (H × W × D) (mm)	2912 × 405 × 175
Net weight (kg)	16.5
Bracket weight (kg)	4.6
Packing weight (kg)	26
Mechanical downtilt	0° - 8°
Mast diameter (mm)	50 - 115
Radome material	Fiberglass
Operating temperature (°C)	- 55 - + 65
Windload frontal (N)	560 (v=150km/h)
Windload lateral (N)	240 (v=150km/h)
Windload rearside (N)	830 (v=150km/h)
Max. wind velocity (km/h)	200
Connector	2×7/16 DIN Female

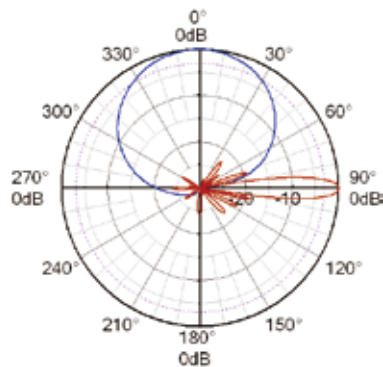
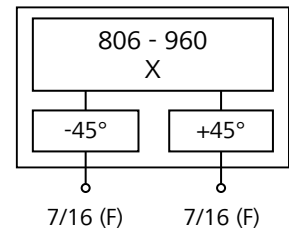

890 - 960 MHz

DX-1710-2170-33-21i-M

Electrical Properties											
Frequency range (MHz)	1710-1880			1850-1990			1920-2170				
Polarization	±45°										
VSWR	≤1.45										
Gain (dBi)	(°)	2	6	10	2	6	10	2	6	10	
	(dB)	20.0	20.3	20.0	20.3	20.6	20.3	20.5	20.8	20.5	
Side lobe suppression for first side lobe above horizon (dB)	(°)	2	6	10	2	6	10	2	6	10	
	(dB)	18	17	17	18	17	17	18	17	17	
3dB beamwidth (horizontal)	34°			32°			30°				
3dB beamwidth (vertical)	7.3°			6.8°			6.2°				
Isolation between portsw (dB)	≥30										
Front to back ratio (dB)	≥30										
Cross polar ratio(dB)	0°	≥20									
	10dB beam width	≥10									
Electrical downtilt	2° - 10°										
Intermodulation IM3 (dBc)	≤-150 (2 × 43 dBm carrier)										
Max. CW input power (W)	300										
Impedance (Ω)	50										
Grounding	DC ground										



Mechanical Properties	
Dimensions (H × W × D) (mm)	1318 × 289 × 85
Packing dimensions (H × W × D) (mm)	1662 × 405 × 175
Net weight (kg)	11.4
Bracket weight (kg)	4.6
Packing weight (kg)	19
Mechanical downtilt	0° - 8°
Mast diameter (mm)	50 - 115
Radome material	Fiberglass
Operating temperature (°C)	- 55 - + 65
Windload frontal (N)	285 (v=150km/h)
Windload lateral (N)	120 (v=150km/h)
Windload rearside (N)	425 (v=150km/h)
Max. wind velocity (km/h)	200
Connector	2×7/16 DIN Female

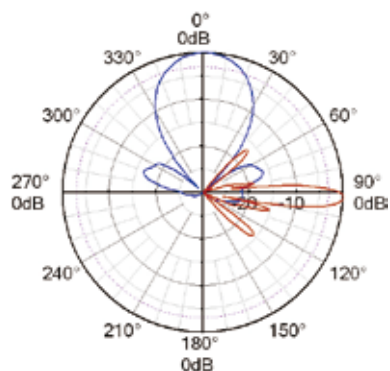
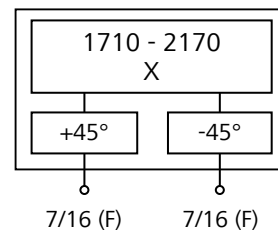

1710 - 1880 MHz

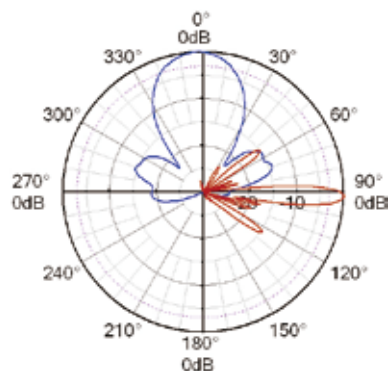

1850 - 1990 MHz

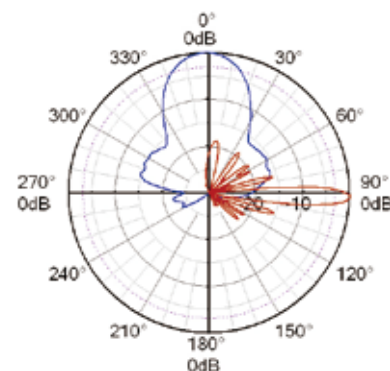

1920 - 2170 MHz

DX-1710-2170-65-18i-0F

Electrical Properties			
Frequency range (MHz)	1710-1880	1850-1990	1920-2170
Polarization	±45°		
VSWR	≤1.4		
Gain (dBi)	17.6	17.8	18.0
Side lobe suppression for first side lobe above horizon (dB)	Typ.20	Typ.20	Typ.20
3dB beamwidth (horizontal)	68°	65°	62°
3dB beamwidth (vertical)	7.3°	6.8°	6.2°
Isolation between ports (dB)	≥30		
Front to back ratio (dB)	Typ.30		
Cross polar ratio(dB)	0°	Typ.21	
	±60°	Typ.10	
Electrical downtilt	0°		
Intermodulation IM3 (dBc)	≤-150 (2 × 43 dBm carrier)		
Max. CW input power (W)	500		
Impedance (Ω)	50		
Grounding	DC ground		

Mechanical Properties	
Dimensions (H × W × D) (mm)	1306 × 155 × 79
Packing dimensions (H × W × D) (mm)	1770 × 260 × 130
Net weight (kg)	5.5
Bracket weight (kg)	3.0
Packing weight (kg)	10.5
Mechanical downtilt	0° - 16°
Mast diameter (mm)	50 - 114
Radome material	Fiberglass
Operating temperature (°C)	- 55 - + 65
Windload frontal (N)	150 (v=150km/h)
Windload lateral (N)	115 (v=150km/h)
Windload rearside (N)	225 (v=150km/h)
Max. wind velocity (km/h)	200
Connector	2×7/16 DIN Female

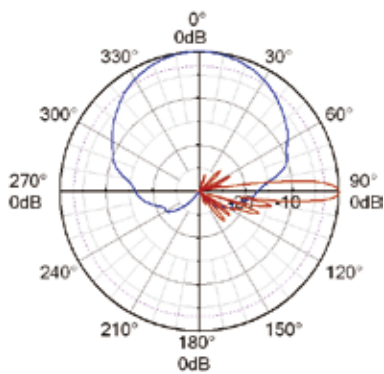
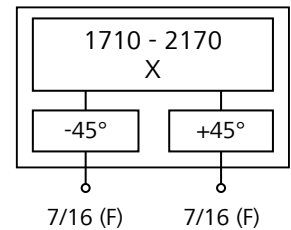

1710 - 1880 MHz

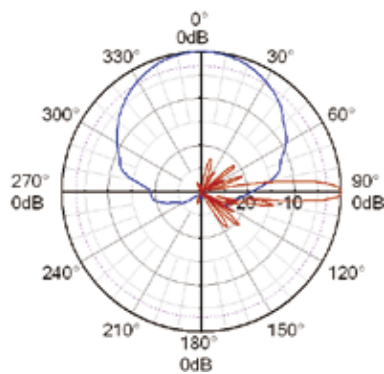

1850 - 1990 MHz

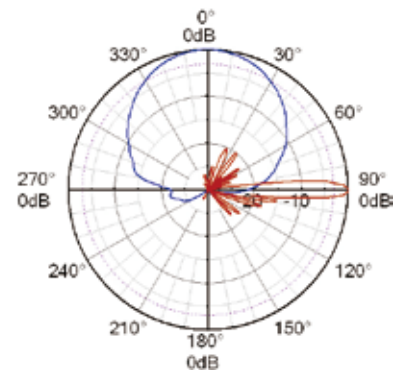

1920 - 2170 MHz

DX-1710-2170-65-18i-2F

Electrical Properties			
Frequency range (MHz)	1710-1880	1850-1990	1920-2170
Polarization	±45°		
VSWR	≤1.4		
Gain (dBi)	17.6	17.8	18.0
Side lobe suppression for first side lobe above horizon (dB)	Typ.20	Typ.20	Typ.20
3dB beamwidth (horizontal)	68°	65°	62°
3dB beamwidth (vertical)	7.3°	6.8°	6.2°
Isolation between ports (dB)	≥30		
Front to back ratio (dB)	Typ.30		
Cross polar ratio(dB)	0°	Typ.21	
	±60°	Typ.10	
Electrical downtilt	2°		
Intermodulation IM3 (dBC)	≤-150 (2 × 43 dBm carrier)		
Max. CW input power (W)	500		
Impedance (Ω)	50		
Grounding	DC ground		

Mechanical Properties	
Dimensions (H × W × D) (mm)	1306 × 155 × 79
Packing dimensions (H × W × D) (mm)	1770 × 260 × 130
Net weight (kg)	5.5
Bracket weight (kg)	3.0
Packing weight (kg)	10.5
Mechanical downtilt	0° - 16°
Mast diameter (mm)	50 - 115
Radome material	Fiberglass
Operating temperature (°C)	- 55 - + 65
Windload frontal (N)	150 (v=150km/h)
Windload lateral (N)	115 (v=150km/h)
Windload rearside (N)	225 (v=150km/h)
Max. wind velocity (km/h)	200
Connector	2×7/16 DIN Female

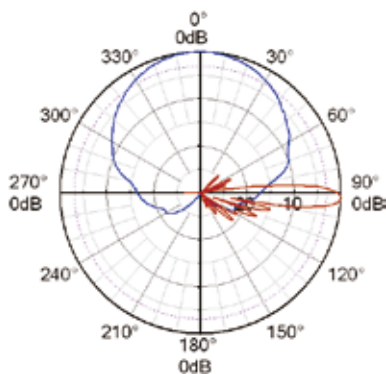
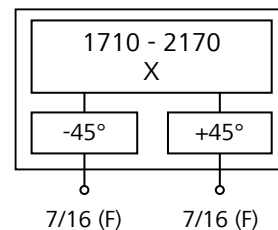

1710 - 1880 MHz

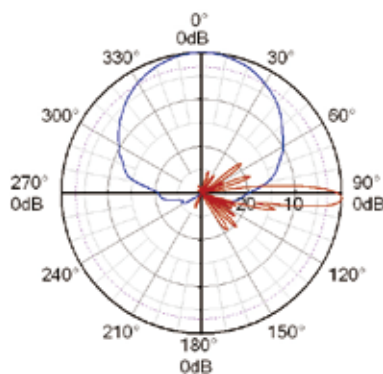

1850 - 1990 MHz

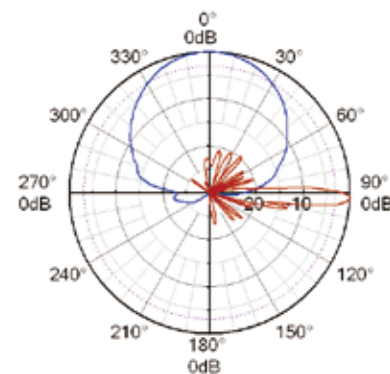

1920 - 2170 MHz

DX-1710-2170-65-18i-3F

Electrical Properties			
Frequency range (MHz)	1710-1880	1850-1990	1920-2170
Polarization	±45°		
VSWR	≤1.4		
Gain (dBi)	17.6	17.8	18.0
Side lobe suppression for first side lobe above horizon (dB)	Typ.20	Typ.20	Typ.20
3dB beamwidth (horizontal)	68°	65°	62°
3dB beamwidth (vertical)	7.3°	6.8°	6.2°
Isolation between ports (dB)	≥30		
Front to back ratio (dB)	Typ.30		
Cross polar ratio(dB)	0°	Typ.21	
	±60°	Typ.10	
Electrical downtilt	3°		
Intermodulation IM3 (dBc)	≤-150 (2 × 43 dBm carrier)		
Max. CW input power (W)	500		
Impedance (Ω)	50		
Grounding	DC ground		

Mechanical Properties	
Dimensions (H × W × D) (mm)	1306 × 155 × 79
Packing dimensions (H × W × D) (mm)	1770 × 260 × 130
Net weight (kg)	5.5
Bracket weight (kg)	3.0
Packing weight (kg)	10.5
Mechanical downtilt	0° - 16°
Mast diameter (mm)	50 - 115
Radome material	Fiberglass
Operating temperature (°C)	- 55 - + 65
Windload frontal (N)	150 (v=150km/h)
Windload lateral (N)	115 (v=150km/h)
Windload rearside (N)	225 (v=150km/h)
Max. wind velocity (km/h)	200
Connector	2×7/16 DIN Female

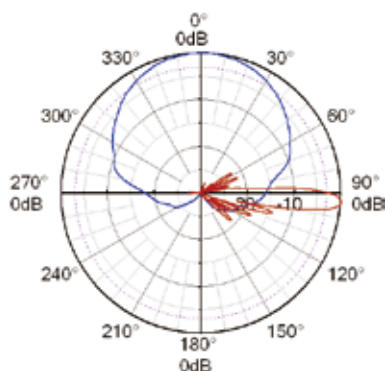
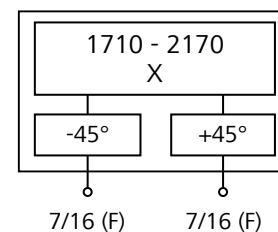

1710 - 1880 MHz

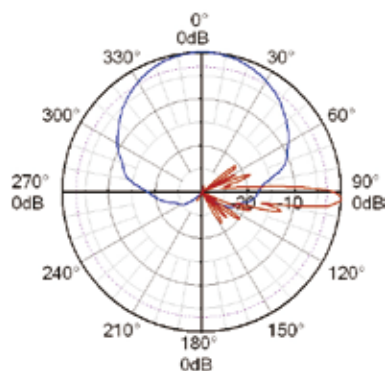

1850 - 1990 MHz

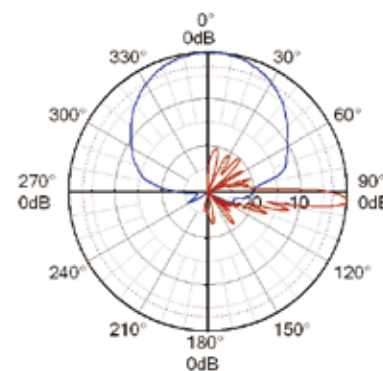

1920 - 2170 MHz

DX-1710-2170-65-18i-6F

Electrical Properties			
Frequency range (MHz)	1710-1880	1850-1990	1920-2170
Polarization	±45°		
VSWR	≤1.4		
Gain (dBi)	17.6	17.8	18.0
Side lobe suppression for first side lobe above horizon (dB)	Typ.20	Typ.20	Typ.20
3dB beamwidth (horizontal)	68°	65°	62°
3dB beamwidth (vertical)	7.3°	6.8°	6.2°
Isolation between ports (dB)	≥30		
Front to back ratio (dB)	Typ.30		
Cross polar ratio(dB)	0°	Typ.21	
	±60°	Typ.10	
Electrical downtilt	6°		
Intermodulation IM3 (dBC)	≤-150 (2 × 43 dBm carrier)		
Max. CW input power (W)	500		
Impedance (Ω)	50		
Grounding	DC ground		

Mechanical Properties	
Dimensions (H × W × D) (mm)	1306 × 155 × 79
Packing dimensions (H × W × D) (mm)	1770 × 260 × 130
Net weight (kg)	5.5
Bracket weight (kg)	3.0
Packing weight (kg)	10.5
Mechanical downtilt	0° - 16°
Mast diameter (mm)	50 - 115
Radome material	Fiberglass
Operating temperature (°C)	- 55 - + 65
Windload frontal (N)	150 (v=150km/h)
Windload lateral (N)	115 (v=150km/h)
Windload rearside (N)	225 (v=150km/h)
Max. wind velocity (km/h)	200
Connector	2×7/16 DIN Female

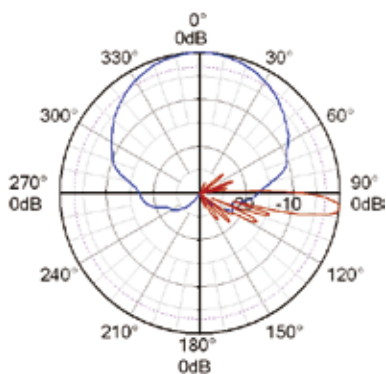
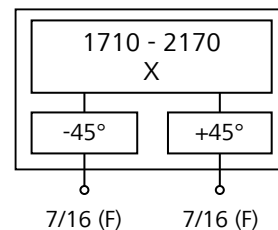

1710 - 1880 MHz

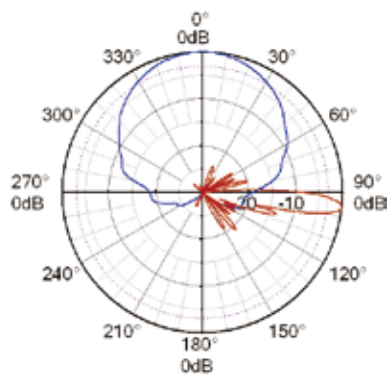

1850 - 1990 MHz

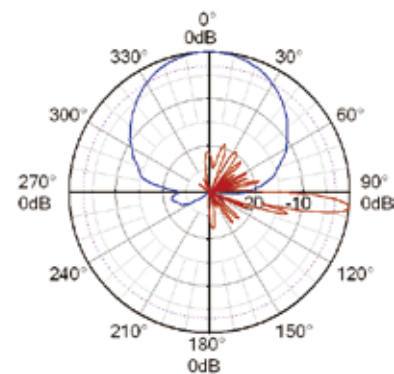

1920 - 2170 MHz

DX-1710-2170-65-18i-M

Electrical Properties										
Frequency range (MHz)	1710-1880			1850-1990			1920-2170			
Polarization	±45°									
VSWR	≤1.4									
Gain (dBi)	(°)	2	6	10	2	6	10	2	6	10
	(dB)	17.8	17.7	17.5	17.9	17.7	17.5	18.0	17.7	17.5
Side lobe suppression for first side lobe above horizon (dB)	(°)	2	6	10	2	6	10	2	6	10
	(dB)	18	17	16	18	17	16	18	18	17
3dB beamwidth (horizontal)	66°			64°			62°			
3dB beamwidth (vertical)	7.5°			6.8°			6.4°			
Isolation between portsw (dB)	≥30									
Front to back ratio (dB)	Typ.30									
Cross polar ratio(dB)	0°	Typ.20								
	±60°	Typ.10								
Electrical downtilt	2° - 10°									
Intermodulation IM3 (dBc)	≤-150 (2 × 43 dBm carrier)									
Max. CW input power (W)	300									
Impedance (Ω)	50									
Grounding	DC ground									

Mechanical Properties	
Dimensions (H × W × D) (mm)	1306 × 155 × 79
Packing dimensions (H × W × D) (mm)	1770 × 260 × 130
Net weight (kg)	6.5
Bracket weight (kg)	3.0
Packing weight (kg)	11.5
Mechanical downtilt	0° - 16°
Mast diameter (mm)	50 - 115
Radome material	Fiberglass
Operating temperature (°C)	- 55 - + 65
Windload frontal (N)	150 (v=150km/h)
Windload lateral (N)	115 (v=150km/h)
Windload rearside (N)	225 (v=150km/h)
Max. wind velocity (km/h)	200
Connector	2×7/16 DIN Female

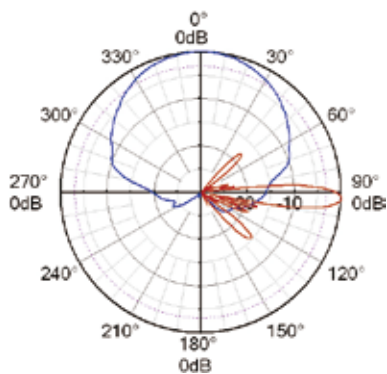
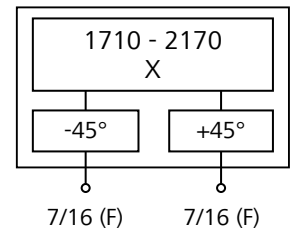

1710 - 1880 MHz

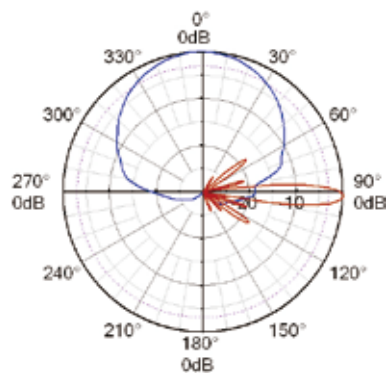

1850 - 1990 MHz

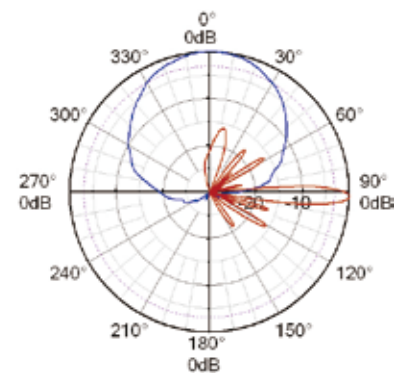

1920 - 2170 MHz

DX-1710-2170-65-19.5i-M

Electrical Properties										
Frequency range (MHz)	1710-1880			1850-1990			1920-2170			
Polarization	±45°									
VSWR	≤1.45									
Gain (dBi)	(°)	2	5	8	2	5	8	2	5	8
	(dB)	18.5	18.7	18.4	19	19.2	18.9	19.3	19.5	19.2
Side lobe suppression for first side lobe above horizon (dB)	(°)	2	5	8	2	5	8	2	5	8
	(dB)	18	17	16	18	17	16	18	17	16
3dB beamwidth (horizontal)	68°			64°			61°			
3dB beamwidth (vertical)	5.0°			4.6°			4.2°			
Isolation between portsw (dB)	≥30									
Front to back ratio (dB)	≥28									
Cross polar ratio(dB)	0°	≥17								
	±60°	≥10								
Electrical downtilt	2° - 8°									
Intermodulation IM3 (dBc)	≤-150 (2 × 43 dBm carrier)									
Max. CW input power (W)	300									
Impedance (Ω)	50									
Grounding	DC ground									

Mechanical Properties	
Dimensions (H × W × D) (mm)	1940 × 155 × 79
Packing dimensions (H × W × D) (mm)	2360 × 255 × 150
Net weight (kg)	8.5
Bracket weight (kg)	4.0
Packing weight (kg)	15.3
Mechanical downtilt	0° - 8°
Mast diameter (mm)	50 - 115
Radome material	Fiberglass
Operating temperature (°C)	- 55 - + 65
Windload frontal (N)	226 (v=150km/h)
Windload lateral (N)	172 (v=150km/h)
Windload rearside (N)	338 (v=150km/h)
Max. wind velocity (km/h)	150
Connector	2×7/16 DIN Female

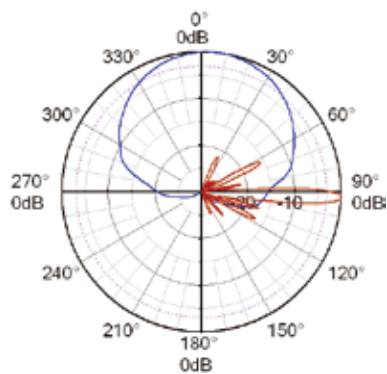
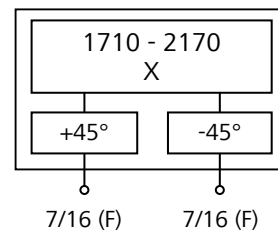

1710 - 1880 MHz

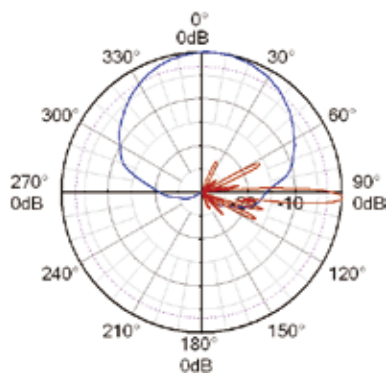

1850 - 1990 MHz

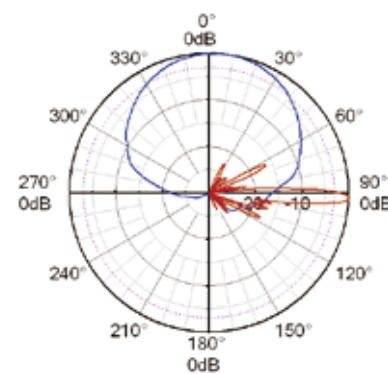

1920 - 2170 MHz

DX-1710-2170-65-21i-0F

Electrical Properties			
Frequency range (MHz)	1710-1880	1850-1990	1920-2170
Polarization	±45°		
VSWR	≤1.45		
Gain (dBi)	20.0	20.5	20.8
Side lobe suppression for first side lobe above horizon (dB)	18		
3dB beamwidth (horizontal)	66°	63°	60°
3dB beamwidth (vertical)	4.2°	3.7°	3.3°
First null_fillbelow main beam (dB)	20		
Isolation between ports (dB)	≥30		
Front to back ratio (dB)	≥30		
Cross polar ratio(dB)	0°	≥17	
	±60°	≥10	
Electrical downtilt	0°		
Intermodulation IM3 (dBC)	≤-150 (2 × 43 dBm carrier)		
Max. CW input power (W)	300		
Impedance (Ω)	50		
Grounding	DC ground		

Mechanical Properties	
Dimensions (H × W × D) (mm)	2170 × 155 × 79
Packing dimensions (H × W × D) (mm)	2580 × 250 × 145
Net weight (kg)	9.1
Bracket weight (kg)	3
Packing weight (kg)	15
Mechanical downtilt	0° - 8°
Mast diameter (mm)	50 - 115
Radome material	Fiberglass
Operating temperature (°C)	- 55 - + 65
Windload frontal (N)	430 (v=150km/h)
Windload lateral (N)	430 (v=150km/h)
Windload rearside (N)	195 (v=150km/h)
Max. wind velocity (km/h)	200
Connector	2×7/16 DIN Female

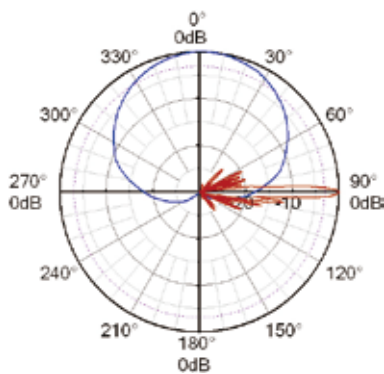
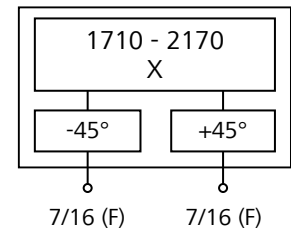

1710 - 1880 MHz

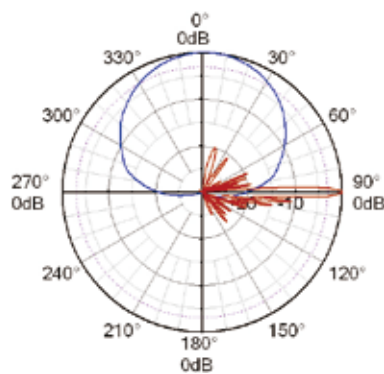

1850 - 1990 MHz

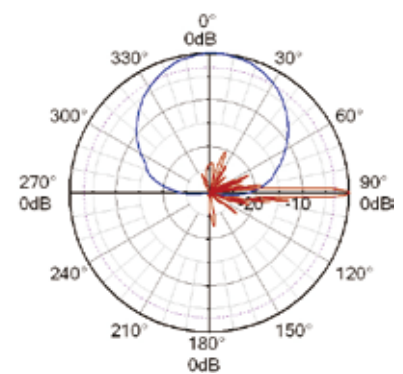

1920 - 2170 MHz

DX-1710-2170-90-17i-0F

Electrical Properties			
Frequency range (MHz)	1710-1880	1850-1990	1920-2170
Polarization	±45°		
VSWR	≤1.5		
Gain (dBi)	16.4	16.9	17.3
Side lobe suppression for first side lobe above horizon (dB)	Typ. 18	Typ. 18	Typ. 18
3dB beamwidth (horizontal)	87°	87°	85°
3dB beamwidth (vertical)	8.5°	7.5°	7.0°
Isolation between ports (dB)	≥30		
Front to back ratio (dB)	≥25		
Cross polar ratio(dB)	0°	≥15	
	±60°	≥10	
Electrical downtilt	0°		
Intermodulation IM3 (dBC)	≤-150 (2 × 43 dBm carrier)		
Max. CW input power (W)	200		
Impedance (Ω)	50		
Grounding	DC ground		

Mechanical Properties	
Dimensions (H × W × D) (mm)	1190 × 176 × 69
Packing dimensions (H × W × D) (mm)	1565 × 280 × 230
Net weight (kg)	5.8
Bracket weight (kg)	2.1
Packing weight (kg)	10.3
Mechanical downtilt	0° - 16°
Mast diameter (mm)	30 - 89
Radome material	Fiberglass
Operating temperature (°C)	- 55 - + 65
Windload frontal (N)	225 (v=150km/h)
Windload lateral (N)	92 (v=150km/h)
Windload rearside (N)	270 (v=150km/h)
Max. wind velocity (km/h)	200
Connector	2×7/16 DIN Female

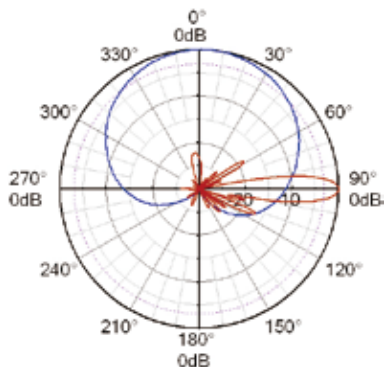
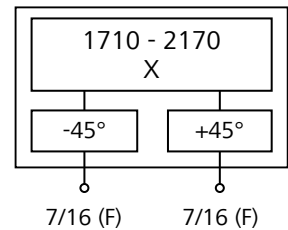

1710 - 1880 MHz

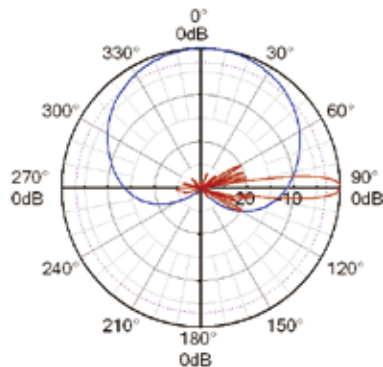

1850 - 1990 MHz

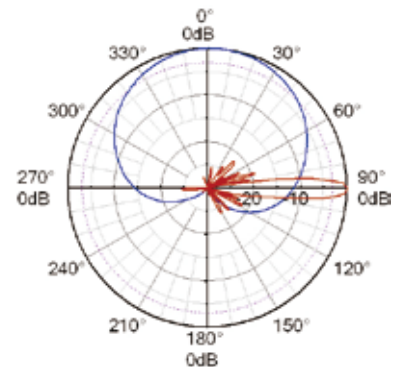

1920 - 2170 MHz

DX-1710-2170-90-17i-2F

Electrical Properties			
Frequency range (MHz)	1710-1880	1850-1990	1920-2170
Polarization	±45°		
VSWR	≤1.5		
Gain (dBi)	16.4	16.9	17.3
Side lobe suppression for first side lobe above horizon (dB)	Typ. 18	Typ. 18	Typ. 18
3dB beamwidth (horizontal)	87°	87°	85°
3dB beamwidth (vertical)	8.5°	7.5°	7.0°
Isolation between ports (dB)	≥30		
Front to back ratio (dB)	≥25		
Cross polar ratio(dB)	0°	≥15	
	±60°	≥10	
Electrical downtilt	2°		
Intermodulation IM3 (dBC)	≤-150 (2 × 43 dBm carrier)		
Max. CW input power (W)	200		
Impedance (Ω)	50		
Grounding	DC ground		

Mechanical Properties	
Dimensions (H × W × D) (mm)	1190 × 176 × 69
Packing dimensions (H × W × D) (mm)	1565 × 280 × 230
Net weight (kg)	5.8
Bracket weight (kg)	2.1
Packing weight (kg)	10.3
Mechanical downtilt	0° - 16°
Mast diameter (mm)	30 - 89
Radome material	Fiberglass
Operating temperature (°C)	- 55 - + 65
Windload frontal (N)	225 (v=150km/h)
Windload lateral (N)	92 (v=150km/h)
Windload rearside (N)	270 (v=150km/h)
Max. wind velocity (km/h)	200
Connector	2×7/16 DIN Female

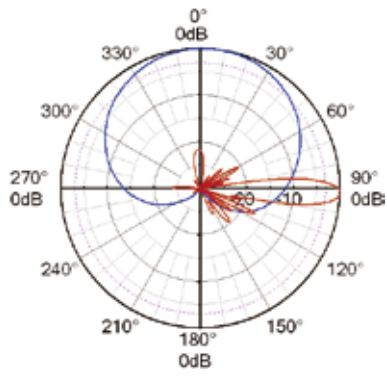
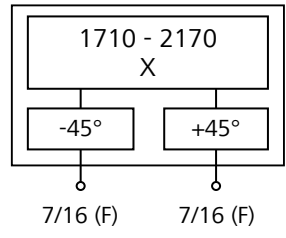

1710 - 1880 MHz

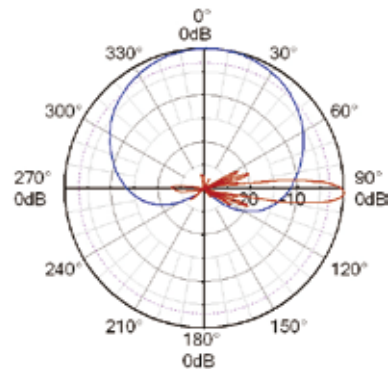

1850 - 1990 MHz

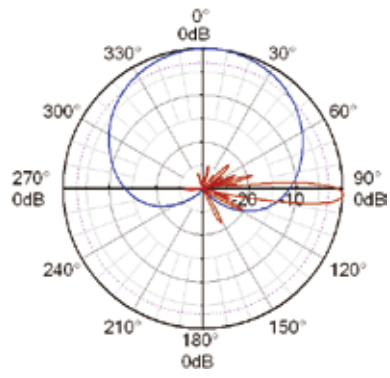

1920 - 2170 MHz

DX-1710-2170-90-17i-6F

Electrical Properties			
Frequency range (MHz)	1710-1880	1850-1990	1920-2170
Polarization	±45°		
VSWR	≤1.5		
Gain (dBi)	16.2	16.7	17.0
Side lobe suppression for first side lobe above horizon (dB)	Typ. 18	Typ. 18	Typ. 18
3dB beamwidth (horizontal)	87°	87°	85°
3dB beamwidth (vertical)	8.5°	7.5°	7.0°
Isolation between ports (dB)	≥30		
Front to back ratio (dB)	≥25		
Cross polar ratio(dB)	0°	≥15	
	±60°	≥10	
Electrical downtilt	6°		
Intermodulation IM3 (dBC)	≤-150 (2 × 43 dBm carrier)		
Max. CW input power (W)	200		
Impedance (Ω)	50		
Grounding	DC ground		

Mechanical Properties	
Dimensions (H × W × D) (mm)	1190 × 176 × 69
Packing dimensions (H × W × D) (mm)	1565 × 280 × 230
Net weight (kg)	5.8
Bracket weight (kg)	2.1
Packing weight (kg)	10.3
Mechanical downtilt	0° - 16°
Mast diameter (mm)	30 - 89
Radome material	Fiberglass
Operating temperature (°C)	- 55 - + 65
Windload frontal (N)	225 (v=150km/h)
Windload lateral (N)	92 (v=150km/h)
Windload rearside (N)	270 (v=150km/h)
Max. wind velocity (km/h)	200
Connector	2×7/16 DIN Female

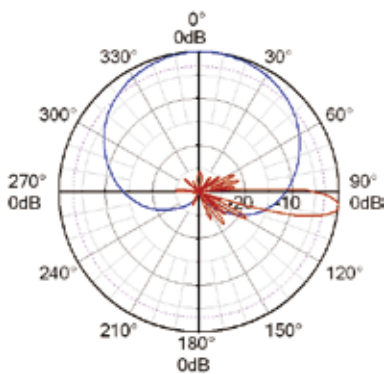
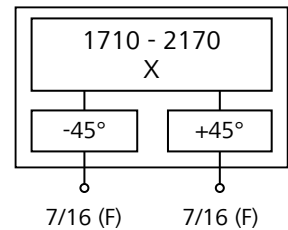

1710 - 1880 MHz

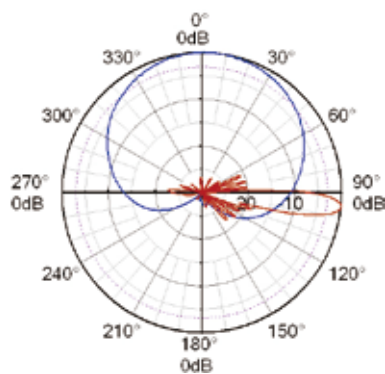

1850 - 1990 MHz

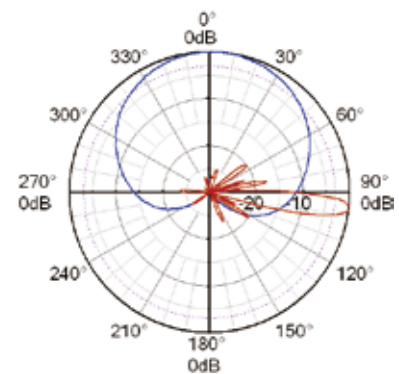

1920 - 2170 MHz

DX-1710-2170-90-17i-M

Electrical Properties										
Frequency range (MHz)	1710-1880			1850-1990			1920-2170			
Polarization	±45°									
VSWR	≤1.4									
Gain (dBi)	(°)	2	6	10	2	6	10	2	6	10
	(dB)	16.3	16.5	16.2	16.5	16.7	16.4	16.7	17.0	16.5
Side lobe suppression for first side lobe above horizon (dB)	(°)	2	6	10	2	6	10	2	6	10
	(dB)	18	17	16	18	17	16	18	17	16
3dB beamwidth (horizontal)	84°			88°			86°			
3dB beamwidth (vertical)	7.5°			6.5°			6.0°			
Isolation between portsw (dB)	≥30									
Front to back ratio (dB)	≥25									
Cross polar ratio(dB)	0°	≥18								
	±60°	≥10								
Electrical downtilt	2° - 10°									
Intermodulation IM3 (dBc)	≤-150 (2 × 43 dBm carrier)									
Max. CW input power (W)	300									
Impedance (Ω)	50									
Grounding	DC ground									

Mechanical Properties	
Dimensions (H × W × D) (mm)	1306 × 155 × 79
Packing dimensions (H × W × D) (mm)	1770 × 260 × 130
Net weight (kg)	6.5
Bracket weight (kg)	3.0
Packing weight (kg)	11.5
Mechanical downtilt	2° - 10°
Mast diameter (mm)	50 - 115
Radome material	Fiberglass
Operating temperature (°C)	- 55 - + 65
Windload frontal (N)	150 (v=150km/h)
Windload lateral (N)	120 (v=150km/h)
Windload rearside (N)	310 (v=150km/h)
Max. wind velocity (km/h)	200
Connector	2×7/16 DIN Female

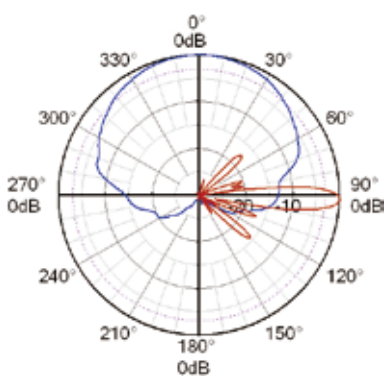
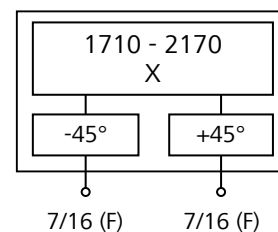

1710 - 1880 MHz

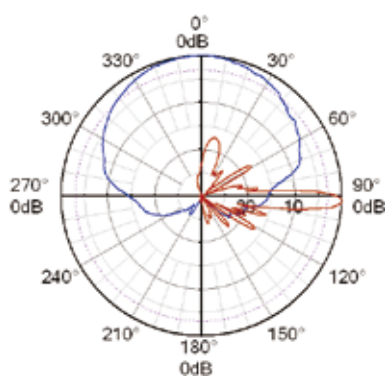

1850 - 1990 MHz

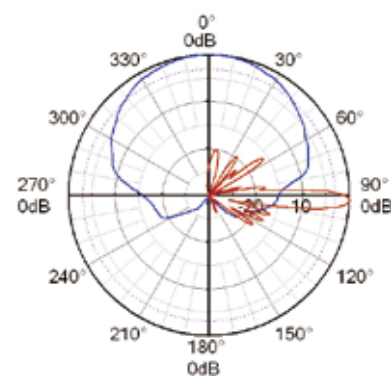

1920 - 2170 MHz

DXX-824-960/1710-2170-65/65-15i/ 17.5i-M/M-C

Electrical Properties																
Frequency range (MHz)	824 -894			880 -960			1710-1880			1850-1990			1920-2170			
Polarization	±45°															
VSWR	≤1.5															
Gain (dBi)	(°)	0	7	14	0	7	14	0	4	8	0	4	8	0	4	8
	(dB)	14.7	14.6	14.5	15.2	15.1	15.0	16.8	17.0	16.7	17.1	17.3	17.0	17.3	17.5	17.2
Side lobe suppression for first side lobe above horizon (dB)	(°)	0	7	14	0	7	14	0	4	8	0	4	8	0	4	8
	(dB)	18	17	16	18	17	16	18	17	16	18	17	16	18	17	16
3dB beamwidth (horizontal)	67°			65°			67°			65°			63°			
3dB beamwidth (vertical)	15.3°			14.5°			8.5°			7.5°			7.0°			
Isolation between portsw (dB)	≥30															
Front to back ratio (dB)	≥28						≥25									
Cross polar ratio(dB)	0°	≥18														
	±60°	≥10														
Electrical downtilt	0° - 14°						0° - 8°									
Intermodulation IM3 (dBc)	≤-150 (2 × 43 dBm carrier)															
Max. CW input power (W)	300						200									
Max. power per combined input (W)	500															
Impedance (Ω)	50															
Grounding	DC ground															



Mechanical Properties	
Dimensions (H × W × D) (mm)	1390 × 368 × 99
Packing dimensions (H × W × D) (mm)	1666 × 498 × 220
Net weight (kg)	18.2
Bracket weight (kg)	4.6
Packing weight (kg)	27.5
Mechanical downtilt	0° - 8°
Mast diameter (mm)	50 - 115
Radome material	Fiberglass
Operating temperature (°C)	- 55 - + 65
Windload frontal (N)	670 (v=150km/h)
Windload lateral (N)	200 (v=150km/h)
Windload rearside (N)	670 (v=150km/h)
Max. wind velocity (km/h)	200
Connector	2 × 7/16 DIN Female

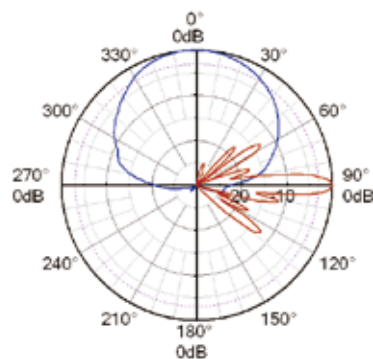
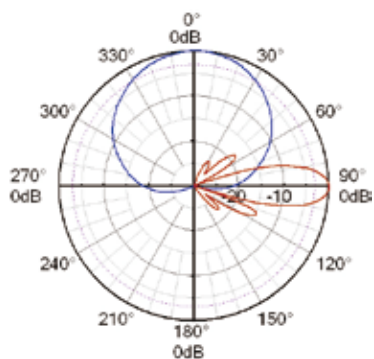
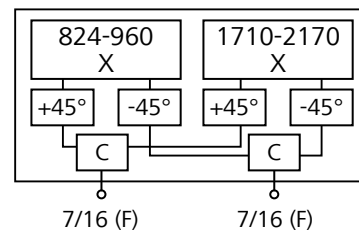

DXX-824-960/1710-2170-65/65-15i/ 18i-M/M

Electrical Properties																
Frequency range (MHz)	824 -894			880 -960			1710-1880			1850-1990			1920-2170			
Polarization	±45°															
VSWR	≤1.5															
Gain (dBi)	(°)	0	7	14	0	7	14	0	4	8	0	4	8	0	4	8
	(dB)	14.8	14.7	14.6	15.3	15.2	15.0	17.0	17.2	16.9	17.3	17.5	17.2	17.6	17.8	17.5
Side lobe suppression for first side lobe above horizon (dB)	(°)	0	7	14	0	7	14	0	4	8	0	4	8	0	4	8
	(dB)	18	17	16	18	17	16	18	17	16	18	17	16	18	17	16
3dB beamwidth (horizontal)	67°			65°			67°			65°			63°			
3dB beamwidth (vertical)	15.3°			14.5°			8.5°			7.5°			7.0°			
Isolation between portsw (dB)	≥28						≥30						≥25			
Front to back ratio (dB)	≥28						≥30						≥25			
	≥28						≥30						≥25			
Cross polar ratio(dB)	0°	≥18														
	±60°	≥10														
Electrical downtilt	0° - 14°						0° - 14°									
Intermodulation IM3 (dBc)	≤-150 (2 × 43 dBm carrier)															
Max. CW input power (W)	500						250									
Impedance (Ω)	50															
Grounding	DC ground															



Dual-band Antennas

Mechanical Properties	
Dimensions (H × W × D) (mm)	1390 × 368 × 99
Packing dimensions (H × W × D) (mm)	1666 × 498 × 220
Net weight (kg)	18.2
Bracket weight (kg)	4.6
Packing weight (kg)	27.5
Mechanical downtilt	0° - 8°
Mast diameter (mm)	50 - 115
Radome material	Fiberglass
Operating temperature (°C)	- 55 - + 65
Windload frontal (N)	670 (v=150km/h)
Windload lateral (N)	200 (v=150km/h)
Windload rearside (N)	670 (v=150km/h)
Max. wind velocity (km/h)	200
Connector	4×7/16 DIN Female

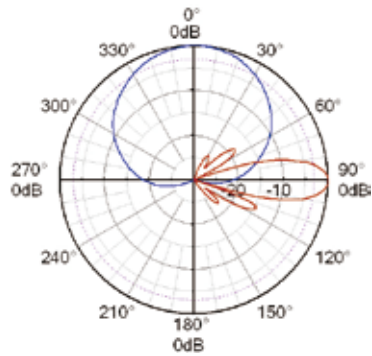
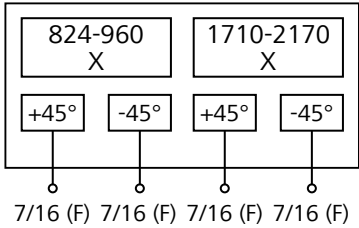

824 - 960 MHz

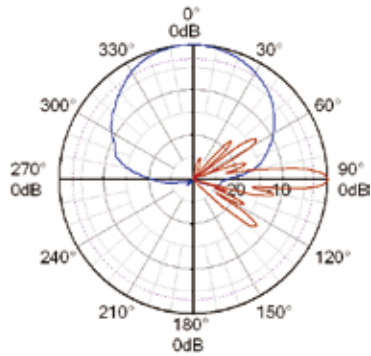

1710 - 2170 MHz

DXX-824-960/1710-2170-65/65-16i/ 17.5i-M/M-C

Electrical Properties																
Frequency range (MHz)	824 -894				880 -960				1710-1880				1850-1990		1920-2170	
Polarization	±45°															
VSWR	≤1.5															
Gain (dBi)	(°)	0	4	8	0	4	8	0	4	8	0	4	8	0	4	8
	(dB)	15.7	15.8	15.6	15.9	16.1	15.8	16.8	17.0	16.7	17.1	17.3	17.0	17.3	17.5	17.2
Side lobe suppression for first side lobe above horizon (dB)	(°)	0	4	8	0	4	8	0	4	8	0	4	8	0	4	8
	(dB)	18	17	16	18	17	16	18	17	16	18	17	16	18	17	16
3dB beamwidth (horizontal)	67°				65°				67°				65°		63°	
3dB beamwidth (vertical)	11.5°				10.5°				8.5°				7.5°		7.0°	
Isolation between ports (dB)	≥30															
Front to back ratio (dB)	≥28							≥25								
Cross polar ratio (dB)	0°	≥18														
	±60°	≥10														
Electrical downtilt	0° - 8°							0° - 8°								
Intermodulation IM3 (dBc)	≤-150 (2 × 43 dBm carrier)															
Max. CW input power (W)	300							200								
Max. power per combined input (W)	500															
Impedance (Ω)	50															
Grounding	DC ground															



Mechanical Properties	
Dimensions (H × W × D) (mm)	1925 × 368 × 99
Packing dimensions (H × W × D) (mm)	2232 × 498 × 220
Net weight (kg)	22.5
Bracket weight (kg)	7.8
Packing weight (kg)	36.5
Mechanical downtilt	0° - 8°
Mast diameter (mm)	50 - 115
Radome material	Fiberglass
Operating temperature (°C)	- 55 - + 65
Windload frontal (N)	910 (v=150km/h)
Windload lateral (N)	270 (v=150km/h)
Windload rearside (N)	910 (v=150km/h)
Max. wind velocity (km/h)	200
Connector	2×7/16 DIN Female

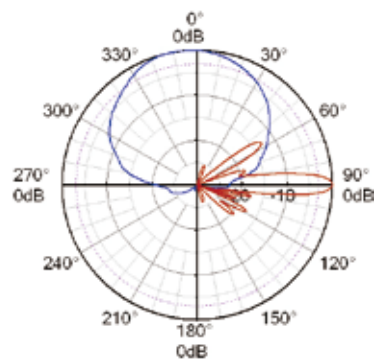
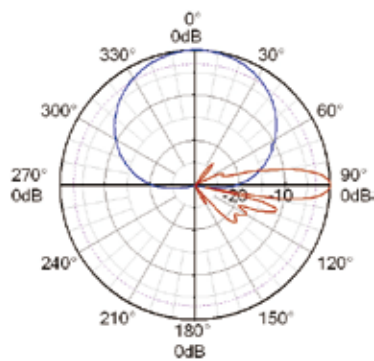
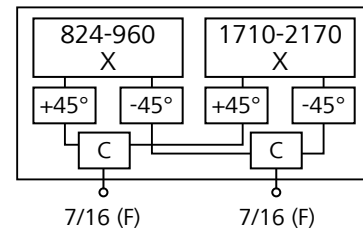

DXX-824-960/1710-2170-65/65-16i/ 18i-M/M

Dual-band Antennas

Electrical Properties																
Frequency range (MHz)	824 -894			880 -960			1710-1880			1850-1990			1920-2170			
Polarization	±45°															
VSWR	≤1.5															
Gain (dBi)	(°)	0	4	8	0	4	8	0	4	8	0	4	8	0	4	8
	(dB)	15.8	16	15.7	16	16.2	15.9	17	17.2	16.9	17.3	17.5	17.2	17.6	17.8	17.5
Side lobe suppression for first side lobe above horizon (dB)	(°)	0	4	8	0	4	8	0	4	8	0	4	8	0	4	8
	(dB)	18	17	16	18	17	16	18	17	16	18	17	16	18	17	16
3dB beamwidth (horizontal)	67°			65°			67°			65°			63°			
3dB beamwidth (vertical)	11.5°			10.5°			8.5°			7.5°			7.0°			
Isolation between ports (dB)	≥30															
Front to back ratio (dB)	≥28						≥25									
Cross polar ratio (dB)	0°	≥18														
	±60°	≥10														
Electrical downtilt	0° - 8°						0° - 8°									
Intermodulation IM3 (dBc)	≤-150 (2 × 43 dBm carrier)															
Max. CW input power (W)	500						250									
Impedance (Ω)	50															
Grounding	DC ground															



Mechanical Properties	
Dimensions (H × W × D) (mm)	1925 × 368 × 99
Packing dimensions (H × W × D) (mm)	2232 × 498 × 220
Net weight (kg)	22.5
Bracket weight (kg)	7.8
Packing weight (kg)	36.5
Mechanical downtilt	0° - 8°
Mast diameter (mm)	50 - 115
Radome material	Fiberglass
Operating temperature (°C)	- 55 - + 65
Windload frontal (N)	910 (v=150km/h)
Windload lateral (N)	270 (v=150km/h)
Windload rearside (N)	910 (v=150km/h)
Max. wind velocity (km/h)	200
Connector	4×7/16 DIN Female

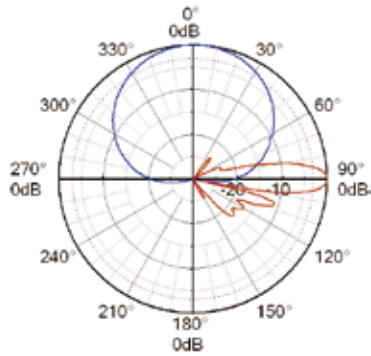
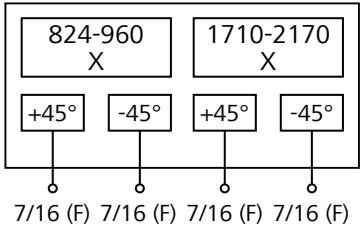

824 - 960 MHz

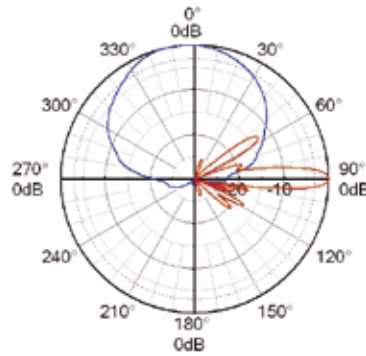

1710 - 2170 MHz

DXX-824-960/1710-2170-65/65-17i/ 17.5i-M/M-C

Electrical Properties																
Frequency range (MHz)	824 -894			880 -960			1710-1880			1850-1990			1920-2170			
Polarization	±45°															
VSWR	≤1.5															
Gain (dBi)	(°)	0	4	8	0	4	8	0	4	8	0	4	8	0	4	8
	(dB)	16.7	16.8	16.5	17.1	17.2	16.9	16.7	16.9	16.6	17.0	17.2	16.9	17.3	17.5	17.2
Side lobe suppression for first side lobe above horizon (dB)	(°)	0	4	8	0	4	8	0	4	8	0	4	8	0	4	8
	(dB)	18	17	16	18	17	16	18	17	16	18	17	16	18	17	16
3dB beamwidth (horizontal)	67°			65°			67°			65°			63°			
3dB beamwidth (vertical)	8.3°			7.2°			8.0°			7.5°			7.0°			
Isolation between portsw (dB)	≥30															
Front to back ratio (dB)	≥28						≥25									
Cross polar ratio(dB)	0°	≥18														
	±60°	≥10														
Electrical downtilt	0° - 8°						0° - 8°									
Intermodulation IM3 (dBc)	≤-150 (2 × 43 dBm carrier)															
Max. CW input power (W)	300						200									
Max. power per combined input (W)	500															
Impedance (Ω)	50															
Grounding	DC ground															



Mechanical Properties	
Dimensions (H × W × D) (mm)	2449 × 368 × 99
Packing dimensions (H × W × D) (mm)	2756 × 498 × 220
Net weight (kg)	26.7
Bracket weight (kg)	7.8
Packing weight (kg)	41.6
Mechanical downtilt	0° - 15°
Mast diameter (mm)	50 - 115
Radome material	Fiberglass
Operating temperature (°C)	- 55 - + 65
Windload frontal (N)	1152 (v=150km/h)
Windload lateral (N)	270 (v=150km/h)
Windload rearside (N)	1152 (v=150km/h)
Max. wind velocity (km/h)	200
Connector	2×7/16 DIN Female

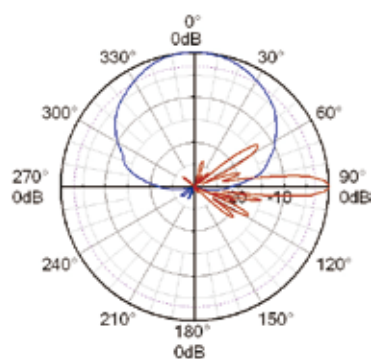
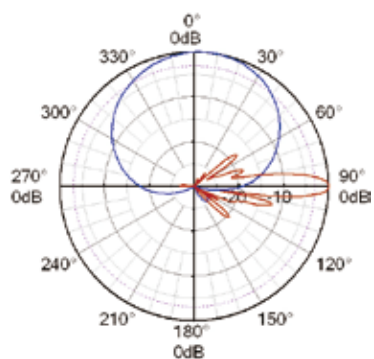
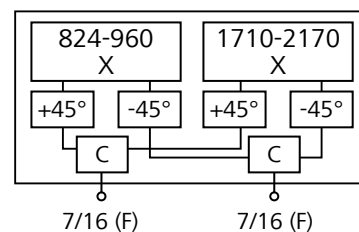

DXX-824-960/1710-2170-65/65-17.5i/18i-M/M

Electrical Properties					
Frequency range (MHz)	824 -894	880 -960	1710-1880	1850-1990	1920-2170
Polarization	±45°				
VSWR	≤1.5				
Gain (dBi)	17.0	17.5	17.0	17.5	18.0
Side lobe suppression for first side lobe above horizon (dB)	Typ. 18	Typ. 18	Typ. 18	Typ. 18	Typ. 18
3dB beamwidth (horizontal)	65°	63°	67°	65°	63°
3dB beamwidth (vertical)	8.5°	7.5°	8.2°	7.5°	7.0°
Isolation between portsw (dB)	≥30				
Front to back ratio (dB)	≥27		≥25		
Cross polar ratio(dB)	0°				
	±60°				
Electrical downtilt	0° - 10°		0° - 8°		
Intermodulation IM3 (dBC)	≤-150 (2 × 43 dBm carrier)				
Max. CW input power (W)	500		250		
Impedance (Ω)	50				
Grounding	DC ground				

Mechanical Properties	
Dimensions (H × W × D) (mm)	2449 × 368 × 99
Packing dimensions (H × W × D) (mm)	2756 × 498 × 220
Net weight (kg)	30
Bracket weight (kg)	7.8
Packing weight (kg)	44
Mechanical downtilt	0° - 15°
Mast diameter (mm)	50 - 115
Radome material	Fiberglass
Operating temperature (°C)	- 55 - + 65
Windload frontal (N)	1000 (v=150km/h)
Windload lateral (N)	270 (v=150km/h)
Windload rearside (N)	1000 (v=150km/h)
Max. wind velocity (km/h)	200
Connector	4x7/16 DIN Female



Dual-band Antennas

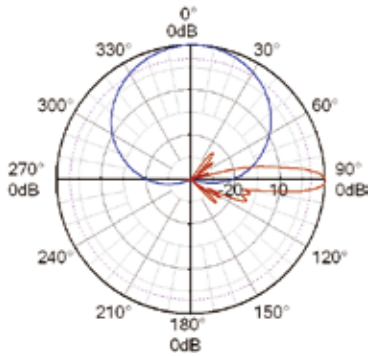
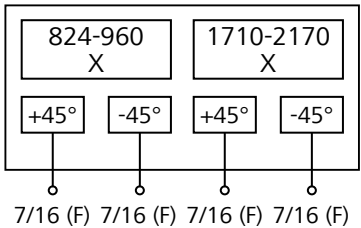

824 - 960 MHz

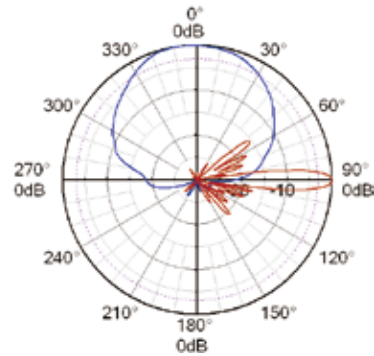

1710 - 2170 MHz

DXX-1710-2170/1710-2170-65/65-18i/ 18i-M/M

Electrical Properties										
Frequency range (MHz)	1710-1880			1850-1990			1920-2170			
Polarization	±45°									
VSWR	≤1.4									
Gain (dBi)	(°)	2	6	10	2	6	10	2	6	10
	(dB)	17.8	17.7	17.5	17.9	17.7	17.5	18.0	17.7	17.5
Side lobe suppression for first side lobe above horizon (dB)	(°)	2	6	10	2	6	10	2	6	10
	(dB)	18	17	16	18	17	16	18	18	17
3dB beamwidth (horizontal)	66°			64°			62°			
3dB beamwidth (vertical)	7.5°			6.8°			6.4°			
Isolation between portsw (dB)	≥30									
Front to back ratio (dB)	Typ. 30									
Cross polar ratio(dB)	0°	Typ. 20								
	±60°	Typ. 10								
Electrical downtilt	2° - 10°									
Intermodulation IM3 (dBc)	≤-150 (2 × 43 dBm carrier)									
Max. CW input power (W)	300									
Impedance (Ω)	50									
Grounding	DC ground									



Mechanical Properties	
Dimensions (H × W × D) (mm)	1306 × 326 × 79
Packing dimensions (H × W × D) (mm)	1715 × 430 × 145
Net weight (kg)	13
Bracket weight (kg)	5
Packing weight (kg)	21
Mechanical downtilt	0° - 16°
Mast diameter (mm)	50 - 115
Radome material	Fiberglass
Operating temperature (°C)	- 55 - + 65
Windload frontal (N)	320 (v=150km/h)
Windload lateral (N)	115 (v=150km/h)
Windload rearside (N)	475 (v=150km/h)
Max. wind velocity (km/h)	200
Connector	4x7/16 DIN Female

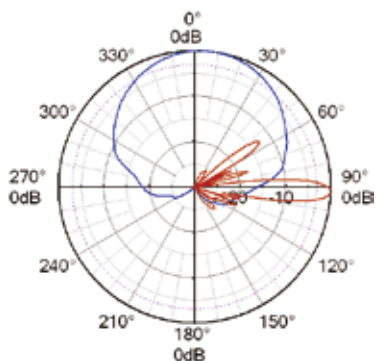
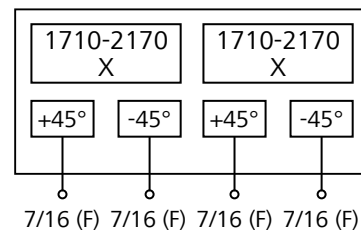

1710 - 1880 MHz

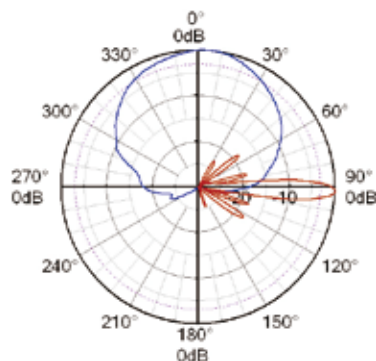

1850 - 1990 MHz

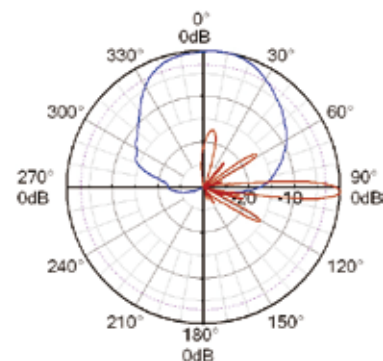

1920 - 2170 MHz

DXXX-824-960/1710-2170/1710-2170-65/ 65/65-16.5i/16.5i/16i-M/M/M

Electrical Properties																
Frequency range (MHz)	824 -894				880 -960				1710-1880				1850-1990		1920-2170	
Polarization	±45°															
VSWR	≤1.5															
Gain	(°)	0	4	8	0	4	8	0	4	8	0	4	8	0	4	8
	824-960 (dBi)	16.0	16.2	15.9	16.3	16.5	16.2									
	1710-2170 Bottom (dBi)							15.8	16.0	15.7	16.1	16.2	15.9	16.3	16.5	16.2
	1710-2170 Top (dBi)							15.3	15.5	15.2	15.6	15.7	15.4	15.8	16.0	15.7
Side lobe suppression for first side lobe above horizon (dB)	(°)	0	4	8	0	4	8	0	4	8	0	4	8	0	4	8
	(dB)	18	17	16	18	17	16	18	17	16	18	17	16	18	17	16
3dB beamwidth (horizontal)	67°				65°				67°				65°		63°	
3dB beamwidth (vertical)	11.5°				10.8°				10.7°				9.9°		9.2°	
Isolation between ports (dB)	≥30															
Front to back ratio (dB)	≥28							≥25								
Cross polar ratio (dB)	0°	Typ. 20														
	±60°	≥10														
Electrical downtilt	0° - 8°							0° - 8°								
Intermodulation IM3 (dBc)	≤-150 (2 × 43 dBm carrier)															
Max. CW input power (W)	500							250								
Impedance (Ω)	50															
Grounding	DC ground															



Triple-band Antennas

Mechanical Properties	
Dimensions (H × W × D) (mm)	1925 × 368 × 99
Packing dimensions (H × W × D) (mm)	2232 × 498 × 220
Net weight (kg)	24.7
Bracket weight (kg)	7.7
Packing weight (kg)	38.7
Mechanical downtilt	0° - 8°
Mast diameter (mm)	50 - 115
Radome material	Fiberglass
Operating temperature (°C)	- 55 - + 65
Windload frontal (N)	910 (v=150km/h)
Windload lateral (N)	270 (v=150km/h)
Windload rearside (N)	910 (v=150km/h)
Max. wind velocity (km/h)	200
Connector	6x7/16 DIN Female

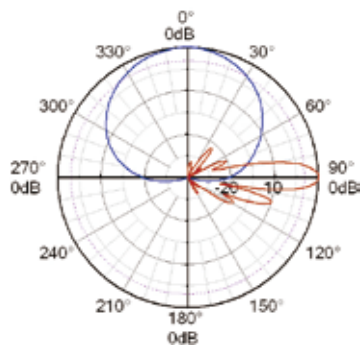
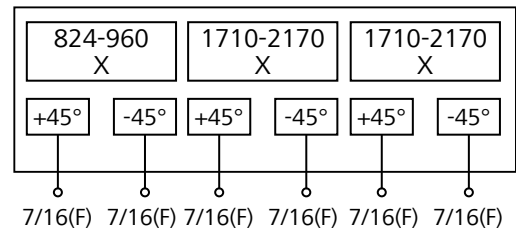

824 - 960 MHz

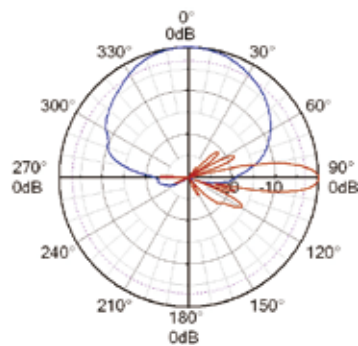

1710 - 2170 MHz

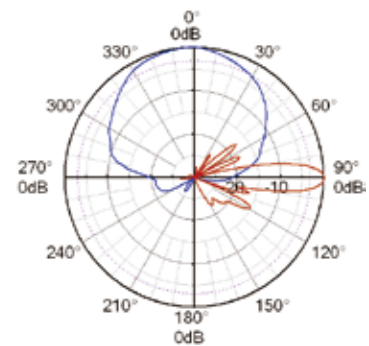

1710 - 2170 MHz

DXXX-824-960/1710-2170/1710-2170-65/65/65-17.5i/17.5i/17i-M/M/M

Triple-band Antennas

Electrical Properties																
Frequency range (MHz)	824 -894			880 -960			1710-1880			1850-1990			1920-2170			
Polarization	±45°															
VSWR	≤1.5															
Gain	(°)	0	4	8	0	4	8	0	4	8	0	4	8	0	4	8
	824-960 (dBi)	16.8	17.0	16.8	17.3	17.5	17.2									
	1710-2170 Bottom (dBi)							16.7	17.0	16.7	16.9	17.3	16.9	17.3	17.5	17.2
	1710-2170 Top (dBi)							16.3	16.6	16.3	16.6	16.9	16.6	16.9	17.1	16.9
Side lobe suppression for first side lobe above horizon (dB)	(°)	0	4	8	0	4	8	0	4	8	0	4	8	0	4	8
	(dB)	18	17	16	18	17	16	18	17	16	18	17	16	18	17	16
3dB beamwidth (horizontal)	67°			65°			67°			65°			63°			
3dB beamwidth (vertical)	8.3°			7.2°			8.0°			7.5°			7.0°			
Isolation between portsw (dB)	≥30															
Front to back ratio (dB)	≥25															
Cross polar ratio(dB)	0°	≥18														
	±60°	≥10														
Electrical downtilt	0° - 8°						0° - 8°									
Intermodulation IM3 (dBc)	≤-150 (2 × 43 dBm carrier)															
Max. CW input power (W)	500						250									
Impedance (Ω)	50															
Grounding	DC ground															



Mechanical Properties	
Dimensions (H × W × D) (mm)	2449 × 368 × 99
Packing dimensions (H × W × D) (mm)	2756 × 498 × 220
Net weight (kg)	30.5
Bracket weight (kg)	7.8
Packing weight (kg)	44
Mechanical downtilt	0° - 15°
Mast diameter (mm)	50 - 115
Radome material	Fiberglass
Operating temperature (°C)	- 55 - + 65
Windload frontal (N)	1000 (v=150km/h)
Windload lateral (N)	270 (v=150km/h)
Windload rearside (N)	1000 (v=150km/h)
Max. wind velocity (km/h)	200
Connector	6x7/16 DIN Female

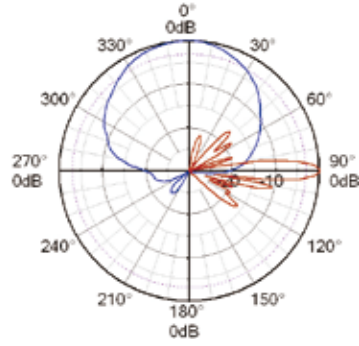
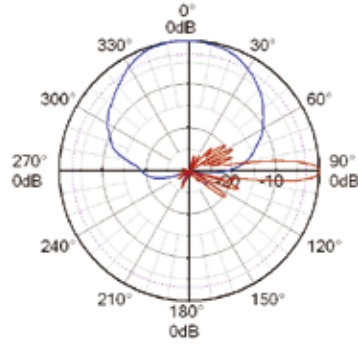
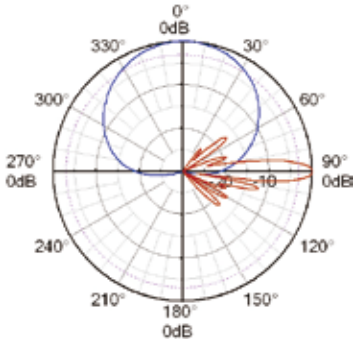
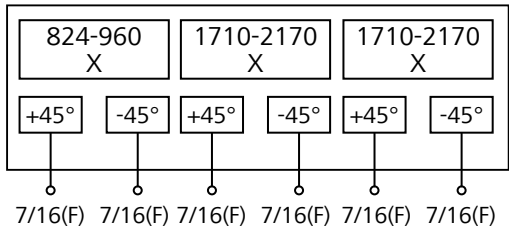

Remote Electrical Tilt (RET)

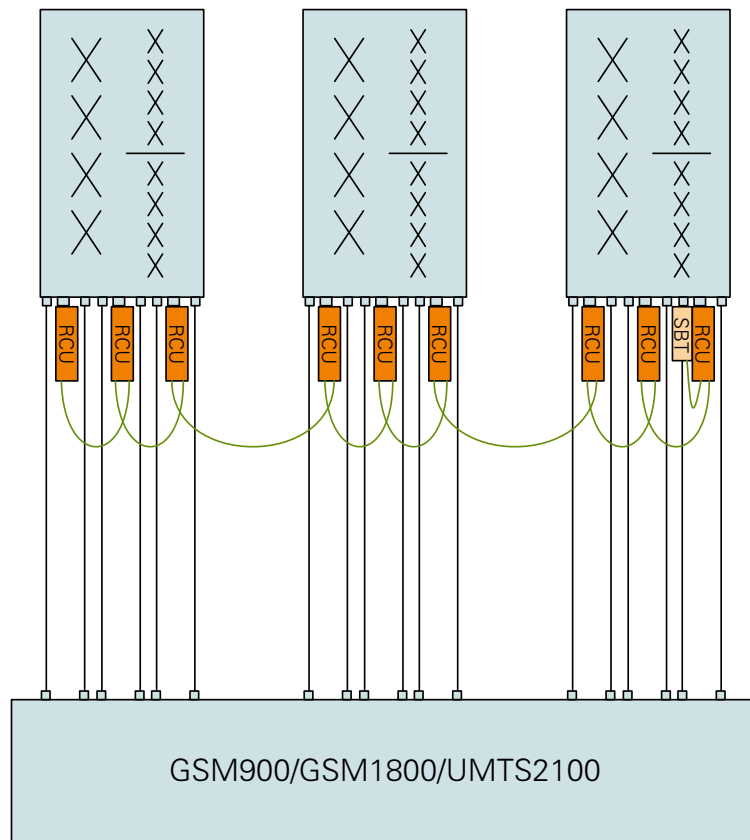

In addition to elimination of network service interruptions, Remote electrical adjustable antennas also allow online or real-time network optimization, reduce the number of site visits, and are not susceptible to weather, facilitating rapid network optimization while decreasing the operation and maintenance OPEX.

When Huawei acquired Huber-Suhner in 2005, the electrical adjustable antennas, their technologies, and related patents were included. With a few years of dedicated research, Huawei Agissoon can now provide full series of single-band, dual-band and triple-band electrical adjustable antennas, which are widely used around the world.

The remote control unit (RCU) is one of the core components in an electrical adjustable antenna system. The built-in motor adjusts the down-tilt angle through the internal phase shifting network activated by motor rotations.



RCU0068/0074/0081/0082/0090/0091/ 0094/0088

- Compliant to AISG1.1 and 3GPP/AISG2.0 protocol.
- Supports the auto-locking function, the mechanical displacement of the already adjusted phase shifter is kept unaltered in the case of power-up or power-off.
- Supports the saving of parameters in the power-off.
- Supports the remote online upgrade of software in an integrated manner.
- Supports the inspection on the movements of the phase shifter.
- Supports the connection to the OMC for integrated management.
- Supports the daisy chain link with a maximum number of cascaded links 27.
- Supports the temperature monitor function (optional).



Type	RCU0068/0074/0081/0082/0090/0091/0094	RCU0088
Electrical performance		
DC voltage (V)	+10 to +30	
Power consumption (mA)	<800 (when the 12-V motor active) ≤50 (when the motor stays static)	
Electrical interface	One 8-pin male connector (IEC 60130-9) is used to input AISG signals and one 8-pin female connector (IEC 60130-9) is used for daisy chain connection with the AISG signals. The pins are defined as follows: 1: DC 2: (N/A) No Application 3:RS-485B 4: N/A 5:RS-485A 6: DC input/output 7: DC loop 8: N/A	
Protocol	AISG1.1	AISG2.0
Mechanical performance		
Mechanical interface	Connect RCU with antenna	
Installation position	Antenna base	
Dimensions (mm)	152 × 56 × 66 (connector excluded)	
Housing material	Housing: aluminum; cover: aluminum	
Weight (kg)	0.65	
Appearance color	Gray	
Environmental performance		
Operating temperature (°C)	-40 to +60	
Protection level	IP24	
Adjustment performance		
Adjust Time (full range) (min)	<2	
Calibration time (min)	<4	

*The correlations of the preceding RCUs and antennas are as follows:

RCU	Antenna Type	Antenna Frequency
RCU0068(AISG V1.1)	DXX-824-960/1710-2170-65/65-17.5i/18i-M/M	1710--2170MHz
	DXX-824-960/1710-2170-65/65-17i/17.5i-M/M-C	1710--2170MHz
	DXX-824-960/1710-2170-65/65-15i/18i-M/M	1710--2170MHz
	DXX-824-960/1710-2170-65/65-15i/17.5i-M/M-C	1710--2170MHz
	DXX-824-960/1710-2170-65/65-16i/18i-M/M	1710--2170MHz
	DXX-824-960/1710-2170-65/65-16i/17.5i-M/M-C	1710--2170MHz
RCU0074(AISG V1.1)	DXX-824-960/1710-2170-65/65-17.5i/18i-M/M	824-960MHz
	DXX-824-960/1710-2170-65/65-17i/17.5i-M/M-C	824-960MHz
RCU0081(AISG V1.1)	DXXX-824-960/1710-2170/1710-2170-65/65/65-17.5i/17.5i/17i-M/M/M	824-960MHz
RCU0082(AISG V1.1)	DXXX-824-960/1710-2170/1710-2170-65/65/65-17.5i/17.5i/17i-M/M/M	1710--2170MHz
RCU0090(AISG V1.1)	DXXX-824-960/1710-2170/1710-2170-65/65/65-16.5i/16.5i/16i-M/M/M	824-960MHz
RCU0091(AISG V1.1)	DXXX-824-960/1710-2170/1710-2170-65/65/65-16.5i/16.5i/16i-M/M/M	1710--2170MHz
RCU0094(AISG V1.1)	DXX-824-960/1710-2170-65/65-16i/18i-M/M	824-960MHz
	DXX-824-960/1710-2170-65/65-16i/17.5i-M/M-C	824-960MHz
RCU0088(AISG V2.0)	DXX-824-960/1710-2170-65/65-15i/18i-M/M	All Frequency
	DXX-824-960/1710-2170-65/65-15i/17.5i-M/M-C	
	DXX-824-960/1710-2170-65/65-16i/18i-M/M	
	DXX-824-960/1710-2170-65/65-16i/17.5i-M/M-C	
	DXX-824-960/1710-2170-65/65-17.5i/18i-M/M	
	DXX-824-960/1710-2170-65/65-17i/17.5i-M/M-C	
	DXXX-824-960/1710-2170/1710-2170-65/65/65-16.5i/16.5i/16i-M/M/M	
DXXX-824-960/1710-2170/1710-2170-65/65/65-17.5i/17.5i/17i-M/M/M		

RCU0075/0089

- Compliant to AISG1.1 and 3GPP/AISG2.0 protocol.
- Supports convenient installation with small sizes
- Supports the auto-locking function, the mechanical displacement of the already adjusted phase shifter is kept unaltered in the case of power-up or power-off.
- Supports the saving of parameters in the power-off.
- Supports the remote online upgrade of software in an integrated manner.
- Supports the inspection on the movements of the phase shifter.
- Supports the connection to the OMC for integrated management.
- Supports the daisy chain link with a maximum number of cascaded links 27.
- Supports the temperature inspection function (optional).



Type	RCU0075	RCU0089
Electrical performance		
DC voltage (V)	+10 to +30	
Power consumption (mA)	<600 (when the 12-V motor active) ≤50 (when the motor stays static)	
Electrical interface	One 8-pin male connector (IEC 60130-9) is used to input AISG signals and one 8-pin female connector (IEC 60130-9) is used for daisy chain connection with the AISG signals. The pins are defined as follows: 1: DC 2: (N/A) No Application 3:RS-485B 4: N/A 5:RS-485A 6: DC input/output 7: DC loop 8: N/A	
Protocol	AISG V1.1	AISG V2.0
Mechanical performance		
Mechanical interface	Connect RCU with antenna	
Installation position	Antenna base	
Dimensions (mm)	157 × 47 × 56 (connector excluded)	
Housing material	Housing: aluminum; cover: aluminum	
Weight (kg)	0.6	
Appearance color	Gray	
Environmental performance		
Working temperature (°C)	-40 to + 60	
Protection level	IP24	
Adjustment performance		
Adjust Time (full range) (min)	<2	
Calibration time (min)	<4	

* The correlations of the preceding RCUs and antennas are as follows:

RCU	Antenna Type	Antenna Frequency
RCU0075(AISG V1.1)	DX-806-960-65-15.5i-M	All Frequency
	DX-806-960-65-17.5i-M	All Frequency
	DX-806-960-90-17i-M	All Frequency
	DX-1710-2170-33-21i-M	All Frequency
	DX-1710-2170-65-18i-M	All Frequency
	DX-1710-2170-65-19.5i-M	All Frequency
	DX-1710-2170-90-17i-M	All Frequency
	DXX-1710-2170/1710-2170-65/65-18i/18i-M/M	All Frequency
RCU0089(AISG V2.0)	DX-806-960-65-15.5i-M	All Frequency
	DX-806-960-65-17.5i-M	All Frequency
	DX-806-960-90-17i-M	All Frequency
	DX-1710-2170-33-21i-M	All Frequency
	DX-1710-2170-65-18i-M	All Frequency
	DX-1710-2170-65-19.5i-M	All Frequency
	DX-1710-2170-90-17i-M	All Frequency
	DXX-1710-2170/1710-2170-65/65-18i/18i-M/M	All Frequency



Base Station Antenna Catalogue

Copyright © Huawei Technologies Co., Ltd. 2009. All rights reserved.

No part of this document may be reproduced or transmitted in any form or by any means without prior written consent of Huawei Technologies Co., Ltd.

Trademark Notice



HUAWEI, and  are trademarks or registered trademarks of Huawei Technologies Co., Ltd.

Other trademarks, product, service and company names mentioned are the property of their respective owners.

NO WARRANTY

THE CONTENTS OF THIS MANUAL ARE PROVIDED "AS IS". EXCEPT AS REQUIRED BY APPLICABLE LAWS, NO WARRANTIES OF ANY KIND, EITHER EXPRESS OR IMPLIED, INCLUDING BUT NOT LIMITED TO, THE IMPLIED WARRANTIES OF MERCHANTABILITY AND FITNESS FOR A PARTICULAR PURPOSE, ARE MADE IN RELATION TO THE ACCURACY, RELIABILITY OR CONTENTS OF THIS MANUAL.

TO THE MAXIMUM EXTENT PERMITTED BY APPLICABLE LAW, IN NO CASE SHALL HUAWEI TECHNOLOGIES CO., LTD BE LIABLE FOR ANY SPECIAL, INCIDENTAL, INDIRECT, OR CONSEQUENTIAL DAMAGES, OR LOST PROFITS, BUSINESS, REVENUE, DATA, GOODWILL OR ANTICIPATED SAVINGS ARISING OUT OF OR IN CONNECTION WITH THE USE OF THIS MANUAL.

HUAWEI TECHNOLOGIES CO., LTD.

Huawei Industrial Base
Bantian Longgang
Shenzhen 518129, P.R. China
Tel: +86-755-28780808
Version No.: M3-308130299-20091125-C-1.0

www.huawei.com